

Enterasys® C3

PoE Gigabit Ethernet Switches

Hardware Installation Guide

C3G124-24P

C3G124-48P



Electrical Hazard: Only qualified personnel should perform installation procedures.

Riesgo Electrico: Solamente personal calificado debe realizar procedimientos de instalacion.

Elektrischer Gefahrenhinweis: Installationen sollten nur durch ausgebildetes und qualifiziertes Personal vorgenommen werden.

Notice

Enterasys Networks reserves the right to make changes in specifications and other information contained in this document and its web site without prior notice. The reader should in all cases consult Enterasys Networks to determine whether any such changes have been made.

The hardware, firmware, or software described in this document is subject to change without notice.

IN NO EVENT SHALL ENTERASYS NETWORKS BE LIABLE FOR ANY INCIDENTAL, INDIRECT, SPECIAL, OR CONSEQUENTIAL DAMAGES WHATSOEVER (INCLUDING BUT NOT LIMITED TO LOST PROFITS) ARISING OUT OF OR RELATED TO THIS DOCUMENT, WEB SITE, OR THE INFORMATION CONTAINED IN THEM, EVEN IF ENTERASYS NETWORKS HAS BEEN ADVISED OF, KNEW OF, OR SHOULD HAVE KNOWN OF, THE POSSIBILITY OF SUCH DAMAGES.

Enterasys Networks, Inc.
50 Minuteman Road
Andover, MA 01810

© 2010 Enterasys Networks, Inc. All rights reserved.

Part Number: 9034277-03 February 2010

ENTERASYS, ENTERASYS NETWORKS, ENTERASYS SECURE NETWORKS, NETSIGHT, ENTERASYS NETSIGHT, and any logos associated therewith, are trademarks or registered trademarks of Enterasys Networks, Inc., in the United States and/or other countries. For a complete list of Enterasys trademarks, see <http://www.enterasys.com/company/trademarks.aspx>.

All other product names mentioned in this manual may be trademarks or registered trademarks of their respective companies.

Documentation URL: <http://www.enterasys.com/support/manuals>

Documentacion URL: <http://www.enterasys.com/support/manuals>

Dokumentation im Internet: <http://www.enterasys.com/support/manuals>

Regulatory Compliance Information

Federal Communications Commission (FCC) Notice

This device complies with Part 15 of the FCC rules. Operation is subject to the following two conditions: (1) this device may not cause harmful interference, and (2) this device must accept any interference received, including interference that may cause undesired operation.

NOTE: This equipment has been tested and found to comply with the limits for a class A digital device, pursuant to Part 15 of the FCC rules. These limits are designed to provide reasonable protection against harmful interference when the equipment is operated in a commercial environment. This equipment uses, generates, and can radiate radio frequency energy and if not installed in accordance with the operator's manual, may cause harmful interference to radio communications. Operation of this equipment in a residential area is likely to cause interference in which case the user will be required to correct the interference at his own expense.

WARNING: Changes or modifications made to this device which are not expressly approved by the party responsible for compliance could void the user's authority to operate the equipment.

Industry Canada Notice

This digital apparatus does not exceed the class A limits for radio noise emissions from digital apparatus set out in the Radio Interference Regulations of the Canadian Department of Communications.

Le présent appareil numérique n'émet pas de bruits radioélectriques dépassant les limites applicables aux appareils numériques de la class A prescrites dans le Règlement sur le brouillage radioélectrique édicté par le ministère des Communications du Canada.

Class A ITE Notice

WARNING: This is a Class A product. In a domestic environment this product may cause radio interference in which case the user may be required to take adequate measures.

Clase A. Aviso de ITE

ADVERTENCIA: Este es un producto de Clase A. En un ambiente doméstico este producto puede causar interferencia de radio en cuyo caso puede ser requerido tomar medidas adecuadas.

Klasse A ITE Anmerkung

WARNHINWEIS: Dieses Produkt zählt zur Klasse A (Industriebereich). In Wohnbereichen kann es hierdurch zu Funkstörungen kommen, daher sollten angemessene Vorkehrungen zum Schutz getroffen werden.

VCCI Notice

This is a class A product based on the standard of the Voluntary Control Council for Interference by Information Technology Equipment (VCCI). If this equipment is used in a domestic environment, radio disturbance may arise. When such trouble occurs, the user may be required to take corrective actions.

この装置は、情報処理装置等電波障害自主規制協議会（VCCI）の基準に基づくクラスA情報技術装置です。この装置を家庭環境で使用すると電波妨害を引き起こすことがあります。この場合には使用者が適切な対策を講ずるよう要求されることがあります。

BSMI EMC Statement — Taiwan

This is a class A product. In a domestic environment this product may cause radio interference in which case the user may be required to take adequate measures.

警告使用者：

這是甲類的資訊產品，在居住的環境中使用時，可能會造成射頻干擾，在這種情況下，使用者會被要求採取某些適當的對策。

AS/NZS CISPR 22



Hazardous Substances

This product complies with the requirements of European Directive, 2002/95/EC, Restriction of Hazardous Substances (RoHS) in Electrical and Electronic Equipment.

European Waste Electrical and Electronic Equipment (WEEE) Notice

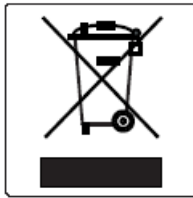

In accordance with Directive 2002/96/EC of the European Parliament on waste electrical and electronic equipment (WEEE):

1. The symbol above indicates that separate collection of electrical and electronic equipment is required and that this product was placed on the European market after August 13, 2005, the date of enforcement for Directive 2002/96/EC.
2. When this product has reached the end of its serviceable life, it cannot be disposed of as unsorted municipal waste. It must be collected and treated separately.
3. It has been determined by the European Parliament that there are potential negative effects on the environment and human health as a result of the presence of hazardous substances in electrical and electronic equipment.
4. It is the users' responsibility to utilize the available collection system to ensure WEEE is properly treated.

For information about the available collection system, please go to www.enterasys.com/services/support/ or contact Enterasys Customer Support at 353 61 705586 (Ireland).

产品说明书附件 Supplement to Product Instructions

部件名称 (Parts)	有毒有害物质或元素 (Hazardous Substance)					
	铅 (Pb)	汞 (Hg)	镉 (Cd)	六价铬 (Cr ⁶⁺)	多溴联苯 (PBB)	多溴二苯醚 (PBDE)
金属部件 (Metal Parts)	×	○	○	○	○	○
电路模块 (Circuit Modules)	×	○	○	○	○	○
电缆及电缆组件 (Cables & Cable Assemblies)	×	○	○	○	○	○
塑料和聚合物部件 (Plastic and Polymeric parts)	○	○	○	○	○	○
电路开关 (Circuit Breakers)	○	○	○	○	○	○

○： 表示该有毒有害物质在该部件所有均质材料中的含量均在 SJ/T 11363-2006 标准规定的限量要求以下。
Indicates that the concentration of the hazardous substance in all homogeneous materials in the parts is below the relevant threshold of the SJ/T 11363-2006 standard.

×： 表示该有毒有害物质至少在该部件的某一均质材料中的含量超出SJ/T 11363-2006 标准规定的限量要求。
Indicates that the concentration of the hazardous substance of at least one of all homogeneous materials in the parts is above the relevant threshold of the SJ/T 11363-2006 standard.

对销售之日的所售产品, 本表显示, 凯创供应链的电子信息产品可能包含这些物质。注意: 在所售产品中可能会也可能不会含有所有所列的部件。
This table shows where these substances may be found in the supply chain of Enterasys' electronic information products, as of the date of sale of the enclosed product. Note that some of the component types listed above may or may not be a part of the enclosed product.

除非另外特别的标注, 此标志为针对所涉及产品的环保使用期标志。某些零部件会有一个不同的环保使用期(例如, 电池单元模块)贴在其产品上。
此环保使用期限只适用于产品是在产品手册中所规定的条件下工作。
The Environmentally Friendly Use Period (EFUP) for all enclosed products and their parts are per the symbol shown here, unless otherwise marked. Certain parts may have a different EFUP (for example, battery modules) and so are marked to reflect such. The Environmentally Friendly Use Period is valid only when the product is operated under the conditions defined in the product manual.



Safety Information Class 1 Laser Transceivers

**The single mode interface modules use Class 1 laser transceivers.
Read the following safety information before installing or operating these modules.**

The Class 1 laser transceivers use an optical feedback loop to maintain Class 1 operation limits. This control loop eliminates the need for maintenance checks or adjustments. The output is factory set, and does not allow any user adjustment. Class 1 Laser transceivers comply with the following safety standards:

- 21 CFR 1040.10 and 1040.11 U.S. Department of Health and Human Services (FDA).
- IEC Publication 825 (International Electrotechnical Commission).
- CENELEC EN 60825 (European Committee for Electrotechnical Standardization).

When operating within their performance limitations, laser transceiver output meets the Class 1 accessible emission limit of all three standards. Class 1 levels of laser radiation are not considered hazardous.

When the connector is in place, all laser radiation remains within the fiber. The maximum amount of radiant power exiting the fiber (under normal conditions) is -12.6 dBm or 55×10^{-6} watts.

Removing the optical connector from the transceiver allows laser radiation to emit directly from the optical port. The maximum radiance from the optical port (under worst case conditions) is 0.8 W cm^{-2} or $8 \times 10^3 \text{ W m}^{-2} \text{ sr}^{-1}$.

Do not use optical instruments to view the laser output. The use of optical instruments to view laser output increases eye hazard. When viewing the output optical port, power must be removed from the network adapter.

Safety Compliance

Warning: Fiber Optic Port Safety

**CLASS I
LASER DEVICE**

When using a fiber optic media expansion module, never look at the transmit laser while it is powered on. Also, never look directly at the fiber TX port and fiber cable ends when they are powered on.

Avertissement: Ports pour fibres optiques - sécurité sur le plan optique

**DISPOSITIF LASER
DE CLASSE I**

Ne regardez jamais le laser tant qu'il est sous tension. Ne regardez jamais directement le port TX (Transmission) à fibres optiques et les embouts de câbles à fibres optiques tant qu'ils sont sous tension.

Warnhinweis: Faseroptikanschlüsse - Optische Sicherheit

**LASERGERÄT
DER KLASSE I**

Niemals ein Übertragungslaser betrachten, während dieses eingeschaltet ist. Niemals direkt auf den Faser-TX-Anschluß und auf die Faserkabelenden schauen, während diese eingeschaltet sind.

Declaration of Conformity

Application of Council Directive(s): **2004/108/EC**
2006/95/EC

Manufacturer's Name: **Enterasys Networks, Inc.**

Manufacturer's Address: **50 Minuteman Road**
Andover, MA 01810
USA

European Representative Name: **Enterasys Networks, Ltd.**

European Representative Address: **Nexus House, Newbury Business Park**
London Road, Newbury
Berkshire RG14 2PZ, England

Conformance to Directive(s)/Product Standards: **EC Directive 2004/108/EC**
EN 55022:2006
EN 55024:1998
EN 61000-3-2:2000
EN 61000-3-3:1995
EC Directive 2006/95/EC
EN 60950-1:2006
EN 60825-1:1994
EN 60825-2:2004

Equipment Type/Environment: **Information Technology Equipment, for use in a Commercial or Light Industrial Environment.**

Enterasys Networks, Inc. declares that the equipment packaged with this notice conforms to the above directives.

ENTERASYS NETWORKS, INC. FIRMWARE LICENSE AGREEMENT

BEFORE OPENING OR UTILIZING THE ENCLOSED PRODUCT, CAREFULLY READ THIS LICENSE AGREEMENT.

This document is an agreement (“Agreement”) between the end user (“You”) and Enterasys Networks, Inc., on behalf of itself and its Affiliates (as hereinafter defined) (“Enterasys”) that sets forth Your rights and obligations with respect to the Enterasys software program/firmware (including any accompanying documentation, hardware or media) (“Program”) in the package and prevails over any additional, conflicting or inconsistent terms and conditions appearing on any purchase order or other document submitted by You. “Affiliate” means any person, partnership, corporation, limited liability company, other form of enterprise that directly or indirectly through one or more intermediaries, controls, or is controlled by, or is under common control with the party specified. This Agreement constitutes the entire understanding between the parties, with respect to the subject matter of this Agreement. The Program may be contained in firmware, chips or other media.

BY INSTALLING OR OTHERWISE USING THE PROGRAM, YOU REPRESENT THAT YOU ARE AUTHORIZED TO ACCEPT THESE TERMS ON BEHALF OF THE END USER (IF THE END USER IS AN ENTITY ON WHOSE BEHALF YOU ARE AUTHORIZED TO ACT, “YOU” AND “YOUR” SHALL BE DEEMED TO REFER TO SUCH ENTITY) AND THAT YOU AGREE THAT YOU ARE BOUND BY THE TERMS OF THIS AGREEMENT, WHICH INCLUDES, AMONG OTHER PROVISIONS, THE LICENSE, THE DISCLAIMER OF WARRANTY AND THE LIMITATION OF LIABILITY. IF YOU DO NOT AGREE TO THE TERMS OF THIS AGREEMENT OR ARE NOT AUTHORIZED TO ENTER INTO THIS AGREEMENT, ENTERASYS IS UNWILLING TO LICENSE THE PROGRAM TO YOU AND YOU AGREE TO RETURN THE UNOPENED PRODUCT TO ENTERASYS OR YOUR DEALER, IF ANY, WITHIN TEN (10) DAYS FOLLOWING THE DATE OF RECEIPT FOR A FULL REFUND.

IF YOU HAVE ANY QUESTIONS ABOUT THIS AGREEMENT, CONTACT ENTERASYS NETWORKS, LEGAL DEPARTMENT AT (978) 684-1000.

You and Enterasys agree as follows:

1. **LICENSE.** You have the non-exclusive and non-transferable right to use only the one (1) copy of the Program provided in this package subject to the terms and conditions of this Agreement.
2. **RESTRICTIONS.** Except as otherwise authorized in writing by Enterasys, You may not, nor may You permit any third party to:
 - (a) Reverse engineer, decompile, disassemble or modify the Program, in whole or in part, including for reasons of error correction or interoperability, except to the extent expressly permitted by applicable law and to the extent the parties shall not be permitted by that applicable law, such rights are expressly excluded. Information necessary to achieve interoperability or correct errors is available from Enterasys upon request and upon payment of Enterasys’ applicable fee.
 - (b) Incorporate the Program in whole or in part, in any other product or create derivative works based on the Program, in whole or in part.
 - (c) Publish, disclose, copy reproduce or transmit the Program, in whole or in part.
 - (d) Assign, sell, license, sublicense, rent, lease, encumber by way of security interest, pledge or otherwise transfer the Program, in whole or in part.
 - (e) Remove any copyright, trademark, proprietary rights, disclaimer or warning notice included on or embedded in any part of the Program.
3. **APPLICABLE LAW.** This Agreement shall be interpreted and governed under the laws and in the state and federal courts of the Commonwealth of Massachusetts without regard to its conflicts of laws provisions. You accept the personal jurisdiction and venue of the Commonwealth of Massachusetts courts. None of the 1980 United Nations Convention on the Limitation Period in the International Sale of Goods, and the Uniform Computer Information Transactions Act shall apply to this Agreement.
4. **EXPORT RESTRICTIONS.** You understand that Enterasys and its Affiliates are subject to regulation by agencies of the U.S. Government, including the U.S. Department of Commerce, which prohibit export or diversion of certain technical products to certain countries, unless a license to export the product is obtained from the U.S. Government or an exception from obtaining such license may be relied upon by the exporting party.

If the Program is exported from the United States pursuant to the License Exception CIV under the U.S. Export Administration Regulations, You agree that You are a civil end user of the Program and agree that You will use the Program for civil end uses only and not for military purposes.

If the Program is exported from the United States pursuant to the License Exception TSR under the U.S. Export Administration Regulations, in addition to the restriction on transfer set forth in Section 1 or 2 of this Agreement, You agree not to (i) reexport or release the Program, the source code for the Program or technology to a national of a country in Country Groups D:1 or E:2 (Albania, Armenia, Azerbaijan, Belarus, Cambodia, Cuba, Georgia, Iraq, Kazakhstan, Laos, Libya, Macau, Moldova, Mongolia, North Korea, the People’s Republic of China, Russia, Tajikistan, Turkmenistan, Ukraine, Uzbekistan,

Vietnam, or such other countries as may be designated by the United States Government), (ii) export to Country Groups D:1 or E:2 (as defined herein) the direct product of the Program or the technology, if such foreign produced direct product is subject to national security controls as identified on the U.S. Commerce Control List, or (iii) if the direct product of the technology is a complete plant or any major component of a plant, export to Country Groups D:1 or E:2 the direct product of the plant or a major component thereof, if such foreign produced direct product is subject to national security controls as identified on the U.S. Commerce Control List or is subject to State Department controls under the U.S. Munitions List.

5. **UNITED STATES GOVERNMENT RESTRICTED RIGHTS.** The enclosed Program (i) was developed solely at private expense; (ii) contains "restricted computer software" submitted with restricted rights in accordance with section 52.227-19 (a) through (d) of the Commercial Computer Software-Restricted Rights Clause and its successors, and (iii) in all respects is proprietary data belonging to Enterasys and/or its suppliers. For Department of Defense units, the Program is considered commercial computer software in accordance with DFARS section 227.7202-3 and its successors, and use, duplication, or disclosure by the U.S. Government is subject to restrictions set forth herein.

6. **DISCLAIMER OF WARRANTY.** EXCEPT FOR THOSE WARRANTIES EXPRESSLY PROVIDED TO YOU IN WRITING BY ENTERASYS, ENTERASYS DISCLAIMS ALL WARRANTIES, EITHER EXPRESS OR IMPLIED, INCLUDING BUT NOT LIMITED TO IMPLIED WARRANTIES OF MERCHANTABILITY, SATISFACTORY QUALITY, FITNESS FOR A PARTICULAR PURPOSE, TITLE AND NON-INFRINGEMENT WITH RESPECT TO THE PROGRAM. IF IMPLIED WARRANTIES MAY NOT BE DISCLAIMED BY APPLICABLE LAW, THEN ANY IMPLIED WARRANTIES ARE LIMITED IN DURATION TO THIRTY (30) DAYS AFTER DELIVERY OF THE PROGRAM TO YOU.

7. **LIMITATION OF LIABILITY.** IN NO EVENT SHALL ENTERASYS OR ITS SUPPLIERS BE LIABLE FOR ANY DAMAGES WHATSOEVER (INCLUDING, WITHOUT LIMITATION, DAMAGES FOR LOSS OF BUSINESS, PROFITS, BUSINESS INTERRUPTION, LOSS OF BUSINESS INFORMATION, SPECIAL, INCIDENTAL, CONSEQUENTIAL, OR RELIANCE DAMAGES, OR OTHER LOSS) ARISING OUT OF THE USE OR INABILITY TO USE THE PROGRAM, EVEN IF ENTERASYS HAS BEEN ADVISED OF THE POSSIBILITY OF SUCH DAMAGES. THIS FOREGOING LIMITATION SHALL APPLY REGARDLESS OF THE CAUSE OF ACTION UNDER WHICH DAMAGES ARE SOUGHT.

THE CUMULATIVE LIABILITY OF ENTERASYS TO YOU FOR ALL CLAIMS RELATING TO THE PROGRAM, IN CONTRACT, TORT OR OTHERWISE, SHALL NOT EXCEED THE TOTAL AMOUNT OF FEES PAID TO ENTERASYS BY YOU FOR THE RIGHTS GRANTED HEREIN.

8. **AUDIT RIGHTS.** You hereby acknowledge that the intellectual property rights associated with the Program are of critical value to Enterasys, and, accordingly, You hereby agree to maintain complete books, records and accounts showing (i) license fees due and paid, and (ii) the use, copying and deployment of the Program. You also grant to Enterasys and its authorized representatives, upon reasonable notice, the right to audit and examine during Your normal business hours, Your books, records, accounts and hardware devices upon which the Program may be deployed to verify compliance with this Agreement, including the verification of the license fees due and paid Enterasys and the use, copying and deployment of the Program. Enterasys' right of examination shall be exercised reasonably, in good faith and in a manner calculated to not unreasonably interfere with Your business. In the event such audit discovers non-compliance with this Agreement, including copies of the Program made, used or deployed in breach of this Agreement, You shall promptly pay to Enterasys the appropriate license fees. Enterasys reserves the right, to be exercised in its sole discretion and without prior notice, to terminate this license, effective immediately, for failure to comply with this Agreement. Upon any such termination, You shall immediately cease all use of the Program and shall return to Enterasys the Program and all copies of the Program.

9. **OWNERSHIP.** This is a license agreement and not an agreement for sale. You acknowledge and agree that the Program constitutes trade secrets and/or copyrighted material of Enterasys and/or its suppliers. You agree to implement reasonable security measures to protect such trade secrets and copyrighted material. All right, title and interest in and to the Program shall remain with Enterasys and/or its suppliers. All rights not specifically granted to You shall be reserved to Enterasys.

10. **ENFORCEMENT.** You acknowledge and agree that any breach of Sections 2, 4, or 9 of this Agreement by You may cause Enterasys irreparable damage for which recovery of money damages would be inadequate, and that Enterasys may be entitled to seek timely injunctive relief to protect Enterasys' rights under this Agreement in addition to any and all remedies available at law.

11. **ASSIGNMENT.** You may not assign, transfer or sublicense this Agreement or any of Your rights or obligations under this Agreement, except that You may assign this Agreement to any person or entity which acquires substantially all of Your stock assets. Enterasys may assign this Agreement in its sole discretion. This Agreement shall be binding upon and inure to the benefit of the parties, their legal representatives, permitted transferees, successors and assigns as permitted by this Agreement. Any attempted assignment, transfer or sublicense in violation of the terms of this Agreement shall be void and a breach of this Agreement.

12. **WAIVER.** A waiver by Enterasys of a breach of any of the terms and conditions of this Agreement must be in writing and will not be construed as a waiver of any subsequent breach of such term or condition. Enterasys' failure to enforce a term upon Your breach of such term shall not be construed as a waiver of Your breach or prevent enforcement on any other occasion.

13. **SEVERABILITY.** In the event any provision of this Agreement is found to be invalid, illegal or unenforceable, the validity, legality and enforceability of any of the remaining provisions shall not in any way be affected or impaired thereby, and that provision shall be reformed, construed and enforced to the maximum extent permissible. Any such invalidity, illegality, or unenforceability in any jurisdiction shall not invalidate or render illegal or unenforceable such provision in any other jurisdiction.

14. **TERMINATION.** Enterasys may terminate this Agreement immediately upon Your breach of any of the terms and conditions of this Agreement. Upon any such termination, You shall immediately cease all use of the Program and shall return to Enterasys the Program and all copies of the Program.

Contents

About This Guide

Who Should Use This Guide	xiii
How to Use This Guide	xiv
Related Documents	xiv
Conventions Used in This Guide	xv
Getting Help	xvi

Chapter 1: Introduction

Overview	1-1
C3G124-24P Stackable Switch	1-1
C3G124-48P Stackable Switch	1-2
High-Speed Stack Connections	1-3
Redundant Power Supply Capability	1-3
PoE (Power over Ethernet) Support	1-4
Connectivity	1-4
Management	1-5
Switch Configuration Using WebView	1-5
Switch Configuration Using CLI Commands	1-5
Standards Compatibility	1-5
LANVIEW Diagnostic LEDs	1-5

Chapter 2: Network Requirements

10BASE-TX Network	2-1
100BASE-TX Network	2-2
1000BASE-FX Network	2-2
1000BASE-T Network	2-2

Chapter 3: Hardware Installation

Considerations Prior to Installation	3-2
Required Tools	3-2
Unpacking the Switch	3-2
Installing Optional Mini-GBICs	3-2
Preparing to Install a Mini-GBIC	3-3
Installing a Mini-GBIC	3-4
Removing a Mini-GBIC	3-5
Installing the Switch on a Flat Surface	3-6
Installing the Rubber Feet	3-6
Guidelines for Flat Surface Installation	3-7
Rack Mounting the Switch 8	
Guidelines for Rackmount Installation	3-8
Attaching Brackets and Installing in Rack	3-8
Connecting High-Speed Stacking Cables	3-9
Configuring Switches in a Stack	3-10
About Switch Operation in a Stack	3-10
Recommended Procedures to Install New and Existing Stacks	3-11
Connecting AC and PoE Power	3-12
AC Power	3-12
PoE Redundant Power System	3-14
Stack Manager Selection	3-14
Connecting to Console Port for Local Management	3-15

What Is Needed	3-15
Connecting to an IBM or Compatible Device	3-16
Connecting to a VT Series Terminal	3-17
Connecting to a Modem	3-18
Connecting to the Network	3-19
Connecting UTP Cables	3-19
Connecting Fiber-Optic Cables to MT-RJ Ports	3-20
Connecting Fiber-Optic Cables to LC Ports	3-22
Completing the Installation	3-24
Initial Logon to Switch Management	3-24

Chapter 4: Troubleshooting

Using LANVIEW	4-2
Troubleshooting Checklist	4-6
Using the Reset Switch	4-7

Appendix A: Specifications

Switch Specifications	A-1
Mini-GBIC Compatibility and Specifications	A-3
Console Port Pinout Assignments	A-3
Regulatory Compliance	A-4

Index

Figures

1-1	C3G124-24P Stackable Switch	1-2
1-2	C3G124-48P Stackable Switch	1-3
3-1	Mini-GBIC with MT-RJ Connector	3-4
3-2	Mini-GBIC with LC Connector	3-5
3-3	Chassis Bottom, Rubber Feet Placement	3-6
3-4	Area Guidelines for Switch Installation on Flat Surface	3-7
3-5	Attaching the Rackmount Brackets	3-8
3-6	Fastening the Switch to the Rack	3-9
3-7	High-Speed Stacking Cable Connections	3-10
3-8	Connecting AC Power and RPS	3-13
3-9	DB9 Male Console Port Pinout Assignments	3-15
3-10	Connecting an IBM PC or Compatible	3-16
3-11	Connecting a VT Series Terminal	3-17
3-12	Connecting to a Modem	3-18
3-13	Connecting a UTP Cable Segment to RJ45 Port	3-19
3-14	Cable Connection to MT-RJ Multimode Fiber-Optic Connectors	3-21
3-15	Cable Connection to LC Fiber-Optic Connectors	3-23
4-1	C3G124-24P LANVIEW LEDs	4-2
4-2	C3G124-48P LANVIEW LEDs	4-3
4-3	Reset Switch	4-7
A-1	Console Port Pinout Assignments	A-3

Tables

1-1	Powered Device Classifications	1-4
4-1	LANVIEW LED Diagnostic Indications	4-4
4-2	Troubleshooting Checklist	4-6
A-1	C3G124-24P and C3G124-48P Specifications	A-1
A-2	Compliance Standards	A-4

About This Guide

This guide provides an overview, installation and troubleshooting instructions, and specifications for the Enterasys® C3G124-24P and C3G124-48P stackable PoE Gigabit Ethernet switches.

For information about the Command Line Interface (CLI) set of commands used to configure and manage the C3G124-24P or C3G124-48P, refer to the *Enterasys C3 Configuration Guide*.

This preface provides an overview of this guide and the C3 manual set, and explains the symbols used throughout this guide.



Note: In this guide, the following terms are used:

- *Switch* refers to both C3G124-24P and C3G124-48P, unless otherwise noted.
- *MGBIC* (Mini-Gigabit Interface Card) refers to optional small form pluggable (SFP) interface modules that plug into the fixed front panel MGBIC slots.
- *PoE* refers to Power over Ethernet (IEEE 802.3af).

Important Notice

Depending on the firmware version used in the switch, some features described in this document may not be supported. Refer to the Release Notes shipped with the switch to determine which features are supported.

Who Should Use This Guide

This guide is intended for a network administrator responsible for installing and setting up the stackable switches.



Electrical Hazard: Only qualified personnel should perform installation procedures.

Riesgo Electrico: Solamente personal calificado debe realizar procedimientos de instalacion.

Elektrischer Gefahrenhinweis: Installationen sollten nur durch ausgebildetes und qualifiziertes Personal vorgenommen werden.

How to Use This Guide

Read through this guide completely to familiarize yourself with its contents and gain an understanding of the features and capabilities of the stackable Ethernet switch. A general knowledge of data communications networks is helpful when setting up the switch.

This guide provides information about the following:

For...	Refer to...
An overview of the switch features and how to obtain technical support	Chapter 1, Introduction
Network requirements that must be met before installing the switch	Chapter 2, Network Requirements
Instructions to install the switch on a flat surface or in a standard 19-inch rack, and configure the switch in a stacked configuration. A description of Power over Ethernet (PoE) is also provided.	Chapter 3, Hardware Installation
Troubleshooting installation problems and diagnosing network/operational problems using the LANVIEW LEDs	Chapter 4, Troubleshooting
Specifications, environmental requirements, and physical properties of the switch and optional Mini-GBICs	Appendix A, Specifications

Related Documents

The following manual can be obtained from the World Wide Web in Adobe Acrobat Portable Document Format (PDF) at the following site:

<http://www.enterasys.com/support/manuals>

Enterasys C3 Configuration Guide describes how to use the Command Line Interface (CLI) to set up and manage the C3 switches.

Conventions Used in This Guide

The following conventions are used in this guide:



Note: Calls the reader's attention to any item of information that may be of special importance.



Caution: Contains information essential to avoid damage to the equipment.

Precaución: Contiene información esencial para prevenir dañar el equipo.

Achtung: Verweist auf wichtige Informationen zum Schutz gegen Beschädigungen.



Electrical Hazard: Warns against an action that could result in personal injury or death due to an electrical hazard.

Riesgo Electrico: Advierte contra una acción que pudiera resultar en lesión corporal o la muerte debido a un riesgo eléctrico.

Elektrischer Gefahrenhinweis: Warnung vor sämtlichen Handlungen, die zu Verletzung von Personen oder Todesfällen – hervorgerufen durch elektrische Spannung – führen können!



Warning: Warns against an action that could result in personal injury or death.

Advertencia: Advierte contra una acción que pudiera resultar en lesión corporal o la muerte.

Warnhinweis: Warnung vor Handlungen, die zu Verletzung von Personen oder gar Todesfällen führen können!

Getting Help

For additional support related to the product or this document, contact Enterasys Networks using one of the following methods:

World Wide Web	www.enterasys.com/services/support/
Phone	1-800-872-8440 (toll-free in U.S. and Canada) or 1-978-684-1000 For the Enterasys Networks Support toll-free number in your country: www.enterasys.com/services/support/contact/
Internet mail	support@enterasys.com To expedite your message, type [C-SERIES] in the subject line.

To send comments concerning this document to the Technical Publications Department:
techpubs@enterasys.com

Please include the document Part Number in your email message.

Before contacting Enterasys Networks for technical support, have the following information ready:

- Your Enterasys Networks service contract number
- A description of the failure
- A description of any action(s) already taken to resolve the problem (for example, changing mode switches or rebooting the unit)
- The serial and revision numbers of all involved Enterasys Networks products in the network
- A description of your network environment (such as layout, cable type, other relevant environmental information)
- Network load and frame size at the time of trouble (if known)
- The device history (for example, if you have returned the device before, or if this a recurring problem)
- Any previous Return Material Authorization (RMA) numbers

Introduction

This chapter introduces the C3G124-24P and C3G124-48P PoE Gigabit Ethernet stackable switches.

For information about...	Refer to page...
Overview	1-1
PoE (Power over Ethernet) Support	1-4
Connectivity	1-4
Management	1-5
Standards Compatibility	1-5
LANVIEW Diagnostic LEDs	1-5

Overview

The C3G124-24P and C3G124-48P are store and forward stackable switches that can be adapted and scaled to help meet your network requirements. These switches provide a management platform and an uplink to a network backbone for a stacked group of up to eight C3 switches.

You can also use a redundant DC power supply with these switches to help prevent downtime due to an internal power supply failure in the switch or AC power source.

You can install the switch on a flat surface or into a standard 19-inch rack with user-supplied mounting hardware, and configure the switch functions using the WebView™ application, CLI switching commands, and/or SNMP.

C3G124-24P Stackable Switch

The C3G124-24P ([Figure 1-1](#)) has several types of front panel port connections, which include:

- Twenty-four RJ45 ports (10/100/1000 Mbps, 1000BASE-T copper ports) that also support PoE for connections to IEEE 802.3af compliant PDs (powered devices).
- Four SFP slots that provide you with the option of installing Small Form Pluggable (SFP) Mini-GBICs for 1000BASE-SX/LX fiber-optic connections and 1000BASE-T copper connections.



Note: The Mini-GBIC ports cannot be active simultaneously with their corresponding 10/100/1000BASE-T ports. For example, if SFP port 24 establishes a link first on the C3G124-24P, the 10/100/1000BASE-T built-in RJ45 port 24 is not available and vice-versa.

- Rear panel connectors for high-speed connections in a stack configuration.

- Rear panel Redundant Power Supply connector used to connect to a PoE-compliant Redundant Power Supply (C2RPS-POE). The switch connects to the C2RPS-POE using a C2RPS-POE cable.



Caution: The C3G124-24P and C3G124-48P are PoE-compliant devices. Do not connect a Redundant Power System (C2RPS-PSM) to the power connector. Otherwise, damage to the device may result.

Precaución: Los dispositivos C3G124-24P y C3G124-48P **cumplen** con el estándar PoE (power over ethernet). **No conecte** una fuente de poder redundante (RPS) (C2RPS-PSM) al cable de corriente. De lo contrario, el dispositivo puede dañarse.

The 10/100/1000 Mbps fixed front panel ports can operate in either half-duplex or full-duplex mode, as determined by Auto-Negotiation.

Figure 1-1 C3G124-24P Stackable Switch

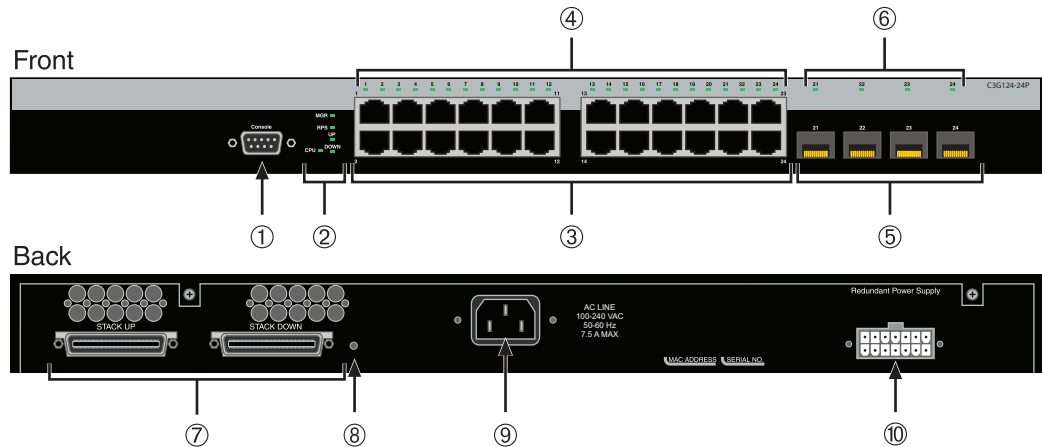

- | | |
|---|--|
| 1 DB9 RS232 console port connector | 6 Mini-GBIC port status LEDs |
| 2 System status LEDs | 7 Two ports for stack connections |
| 3 Twenty-four RJ45, 10/100/1000 Mbps, PoE ports | 8 Password Reset switch |
| 4 RJ45 port status LEDs | 9 AC power input connector |
| 5 Four slots for SFP interface modules (Mini-GBICs) | 10 RPS connector for PoE redundant power supply connection |

C3G124-48P Stackable Switch

The C3G124-48P (Figure 1-2) has several types of front panel port connections, which include:

- Forty-eight RJ45 ports (10/100/1000 Mbps, 1000BASE-T copper ports) that also support PoE for connections to network 803.2af compliant PDs (powered devices).
- Four SFP slots for optional Small Form Pluggable (SFP) Mini-GBICs for 1000BASE-SX/LX fiber-optic connections and 1000BASE-T copper connections.



Note: The Mini-GBIC ports cannot be active simultaneously with their corresponding 10/100/1000BASE-T ports. For example, if SFP port 48 establishes a link first on the C3G124-48P, the 10/100/1000BASE-T built-in RJ45 port 48 is not available and vice-versa.

- Rear panel connectors for high-speed connections in a stack configuration.
- Rear panel Redundant Power Supply connector used to connect to a PoE Redundant Power Supply (C2RPS-POE). The switch connects to the C2RPS-POE using a C2RPS-POE cable.



Caution: The C3G124-24P and C3G124-48P are PoE-compliant devices. Do not connect a Redundant Power System (C2RPS-PSM) to the power connector. Otherwise, damage to the device may result.

Precaución: Los dispositivos C3G124-24P y C3G124-48P **cumplen** con el estándar PoE (power over ethernet). **No conecte** una fuente de poder redundante (RPS) (C2RPS-PSM) al cable de corriente. De lo contrario, el dispositivo puede dañarse.

The 10/100/1000 Mbps fixed front panel ports can operate in either half-duplex or full-duplex mode, as determined by Auto-Negotiation.

Figure 1-2 C3G124-48P Stackable Switch

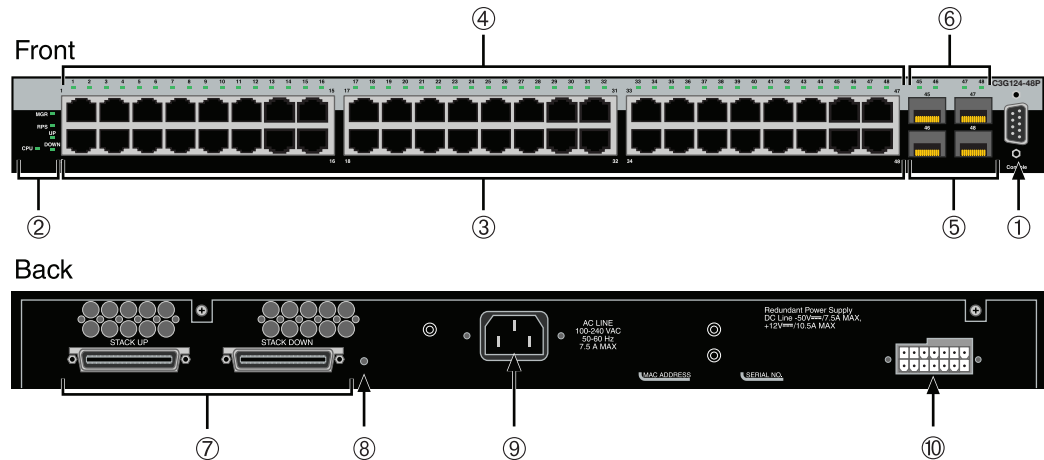

- | | |
|---|--|
| 1 DB9 RS232 console port connector | 6 Mini-GBIC port status LEDs |
| 2 System status LEDs | 7 Two ports for stack connections |
| 3 Forty-eight RJ45, 10/100/1000 Mbps, PoE ports | 8 Password Reset switch |
| 4 RJ45 port status LEDs | 9 AC power input connector |
| 5 Four slots for SFP interface modules (Mini-GBICs) | 10 RPS connector for PoE redundant power supply connection |

High-Speed Stack Connections

The switches have rear-panel connectors for high-speed connections in a stack configuration. The high-speed stacking cables used for the connections are optional items and must be ordered separately. Stacking cables are available in three lengths: 0.3 meter, 1 meter, and 5 meters. See [“Connecting High-Speed Stacking Cables”](#) on page 3-9 for details on these cables.

Redundant Power Supply Capability

The switch has power supply redundancy capability when connected to an optional PoE-compliant external redundant power supply (C2RPS-POE). If the internal power supply fails, the RPS assumes the entire load of the switch without interrupting network traffic. The internal power supply and RPS each have their own AC power connection, which enables the connection of each power supply to a different AC power circuit for additional AC power source redundancy.

PoE (Power over Ethernet) Support

The switch is 802.3af compliant, which means it can provide power over Ethernet cable connections from its 48, RJ45 front panel connectors to PDs in the network.

Power over Ethernet (PoE) refers to the ability to provide 48 Vdc power to a powered device using the same Ethernet cabling that provides data. Modern Ethernet implementations employ differential signals over twisted pair cables. This requires a minimum of two twisted pairs for a single physical link. Both ends of the cable are isolated with transformers blocking any DC or common mode voltage on the signal pair. PoE exploits this fact by using two twisted pairs as the two conductors to supply a direct current. One pair carries the power supply current and the other pair provides a path for the return current. While several proprietary legacy implementations of PoE have been deployed by LAN equipment vendors, in 2003 the IEEE published the IEEE 802.3af-2003 specification, which is part of the 802.3 suite of standards.

The switch is fully compliant with the IEEE 802.3af standard. It supports the standard resistor-based detection method, as well as AC disconnect capability. The switch is also capable of supplying 7.5 watts of power to all ports simultaneously. Support is also provided for the 802.3af-defined maximum of 15.4 watts.

Each PD (Powered Device) has a PDC (Powered Device Classification) that is transmitted to the switch for power management purposes. [Table 1-1](#) lists the classifications and the associated power ranges.

Table 1-1 Powered Device Classifications

Class	Usage	PD Maximum Power Range Usage
None	Default	0.44 to 12.95 Watts
1	Optional	0.44 to 3.84 Watts
2	Optional	3.84 to 6.49 Watts
3	Optional	6.49 to 12.95 Watts
4	Not Allowed	Reserved for Future Use

Connectivity

The switch connects to Ethernet networks or workstations through the fixed front panel RJ45 connectors and four SFP uplink ports that support optional Mini-Gigabit Interface Cards (Mini-GBICs), which are hot swappable. The Mini-GBIC port interface slots can support 1-Gbps fiber-optic and copper connections.

The Mini-GBICs supported and available from Enterasys meet or exceed the IEEE 802.3z-1998 standard. For Mini-GBIC transceiver compatibility and specifications, refer to the datasheet at <http://www.enterasys.com/products/transceivers-ds.pdf>.

Management

Management of the switch can be either in-band or out-of-band. In-band remote management is possible using Telnet, Enterasys Networks' NetSight® management application, or the WebView application. Out-of-band management is provided through the RJ45 COM (Communication) port on the front panel using a VT100 terminal or a VT100 terminal emulator.

Switch Configuration Using WebView

Enterasys Networks' HTTP-based Web management application (WebView) is an intuitive web tool for simple management tasks.

Switch Configuration Using CLI Commands

The CLI commands enable you to perform more complete switch configuration management tasks.

For CLI command set information and how to configure the switch, refer to the *Enterasys C3 Configuration Guide*.

Standards Compatibility

The 1000BASE-T ports are compliant with the following standards and operations:

- IEEE 802.3
- IEEE 802.3u
- IEEE 802.3ab
- Full-Duplex operation

The SFP ports are compliant with the following standards and operations:

- IEEE 802.3z
- IEEE 802.3x Flow Control support for Full-Duplex mode
- Auto-negotiation for Full-Duplex control operation

The stacking port provides 24 Gbps per port connected to Member switches for up and down link connections.

LANVIEW Diagnostic LEDs

LANVIEW diagnostic LEDs serve as an important troubleshooting aid by providing an easy way to observe the status of individual ports and overall network operations.

Refer to "[Using LANVIEW](#)" on page 4-2 for more information.

Network Requirements

Before installing the switch, review the requirements and specifications in this chapter concerning the following:



Note: All RJ45 connectors support PoE connections from network PDs (Powered Devices).

For information about...	Refer to page...
10BASE-TX Network	2-1
100BASE-TX Network	2-2
1000BASE-FX Network	2-2
1000BASE-T Network	2-2



Note: The network installation must meet the requirements described in this chapter to ensure satisfactory performance of this equipment. Failure to do so will produce poor network performance.

10BASE-TX Network

When connecting a 10BASE-TX segment to one of the RJ45 fixed ports on both the C3G124-24P and the C3G124-48P, ensure that the network meets the Ethernet network requirements of the IEEE 802.3-2002 standard for 10BASE-TX.



Note: If a port is to operate at 100 or 1000 Mbps, Category 5 cabling must be used. Category 3 cabling does not meet the 100 or 1000 Mbps specifications. For 10 Mbps operation only, Category 3, Category 4, or Category 5 cabling can be used. Refer to [100BASE-TX Network](#) (page 2-2) and [1000BASE-T Network](#) (page 2-2) for information about 100BASE-TX and 1000BASE-T networks and cabling.

100BASE-TX Network

When connecting a 100BASE-TX segment to one of the RJ45 fixed ports on both the C3G124-24P and the C3G124-48P, use Category 5 UTP cabling. The switch at the other end of the twisted pair segment must meet IEEE 802.3-2002 100BASE-TX Fast Ethernet network requirements for the switches to operate at 100 Mbps.



Note: When using the fixed ports on the switch for 100 Mbps operation use Category 5 UTP cabling with an impedance between 85 and 111 ohms for 100 Mbps operation.

Depending on the switch used, the fixed switch ports are capable of operating at 10 or 100 Mbps, or at 10, 100, or 1000 Mbps. This is accomplished when Auto-Negotiation is enabled, allowing the switch to automatically sense the transmission speed of the other device and adjust for the speed accordingly.

1000BASE-FX Network

The Mini-GBIC port sockets on the C3G124-24P and C3G124-48P enable you to vary the type of 1-Gbps port connection. The device at the other end of the segment must meet the same Gigabit Ethernet requirements for the connected devices to operate at 1-Gigabit speed.

Refer to the datasheet at <http://www.enterasys.com/products/transceivers-ds.pdf> for a list of Mini-GBICs currently available from Enterasys Networks.

1000BASE-T Network

The RJ45 fixed front panel connectors support RJ45 copper 1000BASE-T compliant connections. When connecting a 1000BASE-T segment to one of the RJ45 fixed ports, use Category 5 UTP cabling or better. The device at the other end of the twisted pair segment must meet IEEE 802.3-2002 1000BASE-T Gigabit Ethernet network requirements for the devices to operate at 1000 Mbps.

The C3G124-24P and C3G124-48P can support 1000BASE-T copper connections through MGBIC-02s installed in the MGBIC port slots.

Hardware Installation



Electrical Hazard: Only qualified personnel should perform installation procedures.

Riesgo Electrico: Solamente personal calificado debe realizar procedimientos de instalacion.

Elektrischer Gefahrenhinweis: Installationen sollten nur durch ausgebildetes und qualifiziertes Personal vorgenommen werden.

Important Notice

Read the Release Notes shipped with the switch to check for any exceptions to the supported features and operation documented in this guide.

This chapter provides the instructions to install the C3G124-24P or C3G124-48P. Unless otherwise noted, the instructions apply to both switches. Follow the order of the sections listed below to correctly install the switches.

For information about...	Refer to page...
Considerations Prior to Installation	3-2
Required Tools	3-2
Unpacking the Switch	3-2
Installing Optional Mini-GBICs	3-2
Installing the Switch on a Flat Surface	3-6
Rack Mounting the Switch	3-8
Connecting High-Speed Stacking Cables	3-9
Configuring Switches in a Stack	3-10
Connecting AC and PoE Power	3-12
Connecting to Console Port for Local Management	3-15
Connecting to the Network	3-19
Completing the Installation	3-24

Considerations Prior to Installation

When installing the switch, note the following:

- Before starting the installation procedure, notify the network administrator of the installation.
- Follow the installation procedures in the order as presented in this guide.
- Do not connect the switch to the network until you have established the correct IP address.

Required Tools

A Phillips screwdriver is required to install the switch into a rack.

Unpacking the Switch

Unpack the switch as follows:

1. Open the box and remove the packing material protecting the switch.
2. Verify that the contents of the carton contains the items listed in the following table.

Item	Quantity
C3G124-24P or C3G124-48P switch device	1
Rack mounting bracket	2
M3x6-mm flathead screws	8
Rubber feet with adhesive backing for installation on a flat surface	4
AC power cord (The type of power cord is country-dependent.)	1
DB9 female-to-DB9 female Console Cable	1
This installation guide	1
Customer Release Notes	1
URL notice card	1

3. Remove the tape seal on the non-conductive bag to remove the switch.
4. Perform a visual inspection of the switch for any signs of physical damage. Contact Enterasys Networks if there are any signs of damage. Refer to [“Getting Help”](#) on page xvi for details.

Installing Optional Mini-GBICs

This section describes how to install Mini-GBICs in any of the SFP port slots. It is recommended that the options be installed first in a new installation.



Warning: Do not use optical instruments to view laser output. The use of optical instruments to view laser output increases eye hazard.

Advertencia: No utilizar instrumentos opticos para ver el laser. El uso de instrumentos opticos para ver el laser incrementa el riesgo de perdida de la vision.

Warnhinweis: Benutzen sie keinesfalls optische Hilfsmittel, um die Funktion des Lasers zu überprüfen, es könnte ihr Augenlicht gefährden.



Caution: Carefully follow the instructions in this manual to avoid damaging the Mini-GBIC and switch.

The Mini-GBIC and switch are sensitive to static discharges. Use an antistatic wrist strap and observe all static precautions during this procedure. Failure to do so could result in damage to the Mini-GBIC and switch. Always leave the Mini-GBIC in the antistatic bag or an equivalent antistatic container when not installed.

Precaución: Siga las instrucciones del manual para no dañar el Mini-GBIC ni del aparato, puesto que son muy sensible a las descargas de electricidad estática. Utilice la pulsera antiestática y tome todas las precauciones necesarias durante este procedimiento. Si no lo hace, podría dañar el Mini-GBIC o del aparato. Mientras no esté instalado, mantenga el Mini-GBIC en su bolsa antiestática o en cualquier otro recipiente antiestático.

Preparing to Install a Mini-GBIC

Before removing the Mini-GBIC from the antistatic packaging, it is recommended that you use an antistatic wrist strap (not supplied) to prevent damage from static discharge. To use the wrist strap, refer to the instructions provided with your antistatic wrist strap.

1. Remove the Mini-GBIC from its packaging.
2. If there is a protective dust cover (see 5 in [Figure 3-1](#) or [Figure 3-2](#)) in the Mini-GBIC connector, do not remove it at this time.

Installing a Mini-GBIC

To install a Mini-GBIC that has an MT-RJ connector, refer to [Figure 3-1](#), or for a Mini-GBIC with an LC connector, refer to [Figure 3-2](#), and proceed as follows:

1. Hold the Mini-GBIC with the top side positioned as shown, and the 7-pin edge connector facing the port slot.
2. Carefully align the Mini-GBIC with the port slot.
3. Push the Mini-GBIC into the port slot until the Mini-GBIC “clicks” and locks into place.

Figure 3-1 Mini-GBIC with MT-RJ Connector

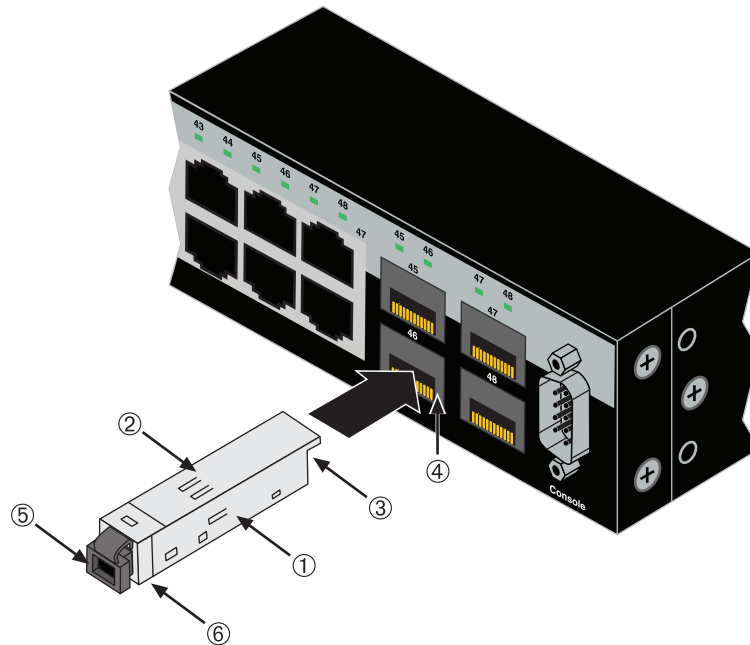

- | | |
|---|-------------------------|
| 1 Mini-GBIC (MGBIC-MT01) | 4 Port slot |
| 2 Mini-GBIC, top side | 5 Protective dust cover |
| 3 7-pin edge connector (insertion side) | 6 Release tab |

Figure 3-2 Mini-GBIC with LC Connector

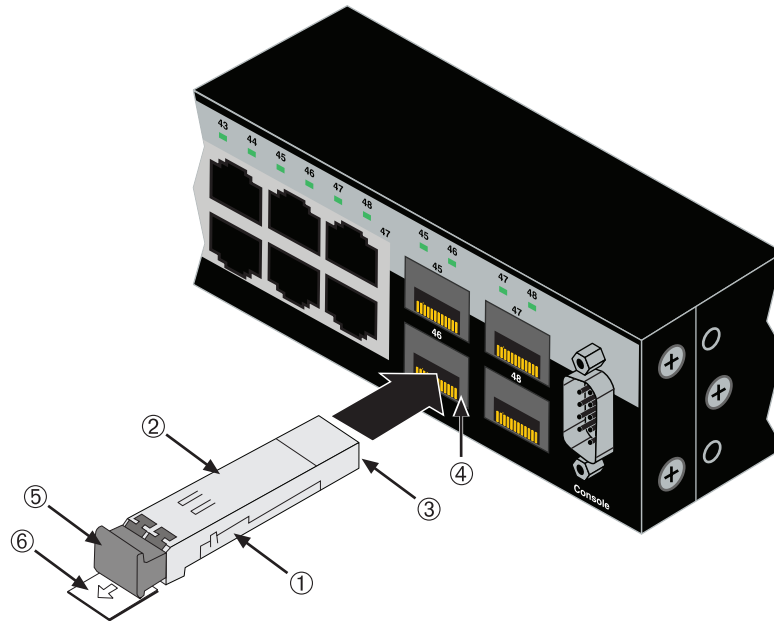

- | | |
|---|-------------------------|
| 1 Mini-GBIC (MGBIC-LC01, -LC03, or -LC09) | 4 Port slot |
| 2 Mini-GBIC, top side | 5 Protective dust cover |
| 3 7-pin edge connector (insertion side) | 6 Release tab |

Removing a Mini-GBIC



Caution: Do NOT remove a Mini-GBIC from a slot without releasing the locking tab located at the front of the Mini-GBIC. This can damage the Mini-GBIC. The Mini-GBIC and its host device are sensitive to static discharges. Use an antistatic wrist strap and observe all static precautions during this procedure. Failure to do so could result in damaging the Mini-GBIC or host device. Always leave the Mini-GBIC in the antistatic bag or an equivalent antistatic container when not installed.

Precaución: NO quite el Mini-GBIC de la ranura sin antes abrir la traba ubicada en la parte frontal del Mini-GBIC. Si lo hace, puede dañar el Mini-GBIC, puesto que es muy sensible a las descargas de electricidad estática, al igual que el dispositivo host. Utilice la pulsera antiestática y tome todas las precauciones necesarias durante este procedimiento. Si no lo hace, puede dañar el Mini-GBIC o el dispositivo host. Mientras no esté instalado, mantenga el Mini-GBIC en su bolsa antiestática o en cualquier otro recipiente antiestático.

To remove a Mini-GBIC from a port slot, refer back to [Figure 3-1](#) and [Figure 3-2](#), and proceed as follows:

1. Attach your antistatic wrist strap (refer to the instructions in your antistatic wrist strap package) before removing the Mini-GBIC.
2. Remove the cables connected to the Mini-GBIC.
3. Locate the release tab under the front end of the Mini-GBIC. For the type of Mini-GBIC shown in [Figure 3-1](#), push in on the release tab as far as it will go to release the Mini-GBIC from the port slot. For the type of Mini-GBIC shown in [Figure 3-2](#), pull out on the release tab to release the Mini-GBIC from the port slot.
4. Grasp the sides of the Mini-GBIC and pull it straight out of the port slot.

If you are storing or shipping a Mini-GBIC, which has a fiber-optic connector, insert its protective dust cover to protect the ends of the fiber-optic fibers from dust and contamination.

Installing the Switch on a Flat Surface

When installing the switch on a flat surface, the installation of the rubber feet is recommended to prevent the switch from sliding on a flat surface. Installing the rubber feet is optional if you are installing the switch in a rack. To install the rubber feet, proceed to [Installing the Rubber Feet](#) below. For instructions to rack mount the switch, proceed to [“Rack Mounting the Switch”](#) on page 3-8.

Installing the Rubber Feet

To install the rubber feet, refer to [Figure 3-3](#) and proceed as follows:

1. Place the switch on its back on a sturdy flat surface to gain access to the bottom of the chassis.
2. Remove the four rubber feet from their plastic bag in the shipping box.
3. Locate the four marked locations on the bottom four corners of the chassis.

Figure 3-3 Chassis Bottom, Rubber Feet Placement

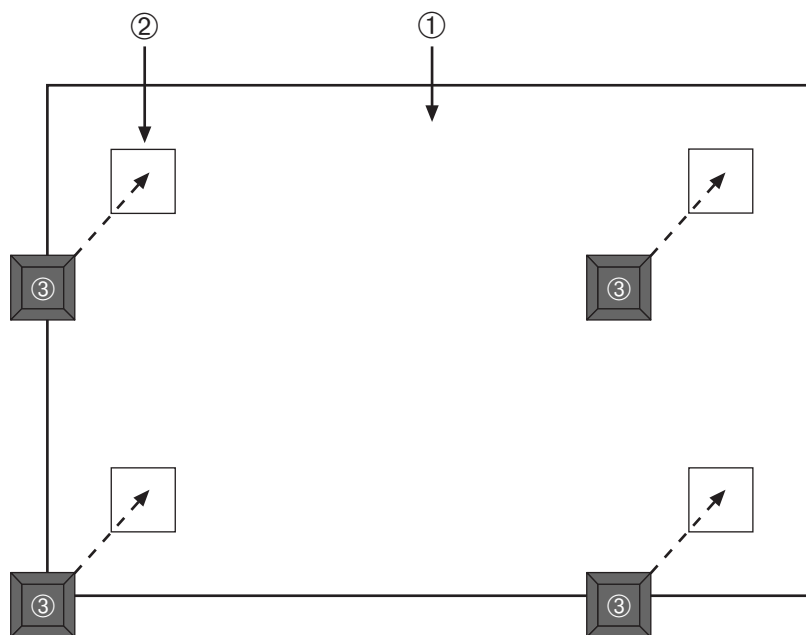

- 1 Bottom of chassis as seen when chassis is resting on its back
 - 2 Locations to install the rubber feet (four locations)
 - 3 Rubber feet with adhesive backing (four)
-
4. Remove the protective strip from the back of one rubber foot and position it on a marked location and press firmly into place. Repeat this procedure to install the remaining three rubber feet.
 5. After installing the rubber feet, return the switch to its upright position.



Note: If a number of switches are being installed in a stack, repeat steps 1 through 4 to install the rubber feet on each switch before continuing with the installation.

- To install switches on a flat surface, proceed to [Guidelines for Flat Surface Installation](#). For a rackmount installation, proceed to “[Rack Mounting the Switch](#)” on page 3-8.

Guidelines for Flat Surface Installation

Locate the switch within 152 cm (5 ft) of its power source and on a surface as shown in [Figure 3-4](#). If an optional redundant power system is going to be installed and connected to the 14-pin Redundant Power Supply input connector on the rear of the switch, refer to the installation guide shipped with the redundant power system.



Caution: To ensure proper ventilation and prevent overheating, leave a minimum clearance space of 5.1 cm (2.0 in.) at the left, right, and rear of the switch.

Do not connect the switch to the primary power source until instructed to do so later in the installation process.

Precaución: Para asegurar una buena ventilación y evitar que el sistema se sobrecaliente, deje un espacio mínimo de 5.1 cm (2 pulgadas) con respecto a los lados y a la parte posterior del aparato.

No conecte el dispositivo a la fuente primaria hasta que no se le indique.

If you are installing several switches in a stack, proceed to “[Connecting High-Speed Stacking Cables](#)” on page 3-9. If the switch is being installed as a standalone switch, proceed to “[Connecting AC and PoE Power](#)” on page 3-12 for power connection instructions.

Figure 3-4 Area Guidelines for Switch Installation on Flat Surface

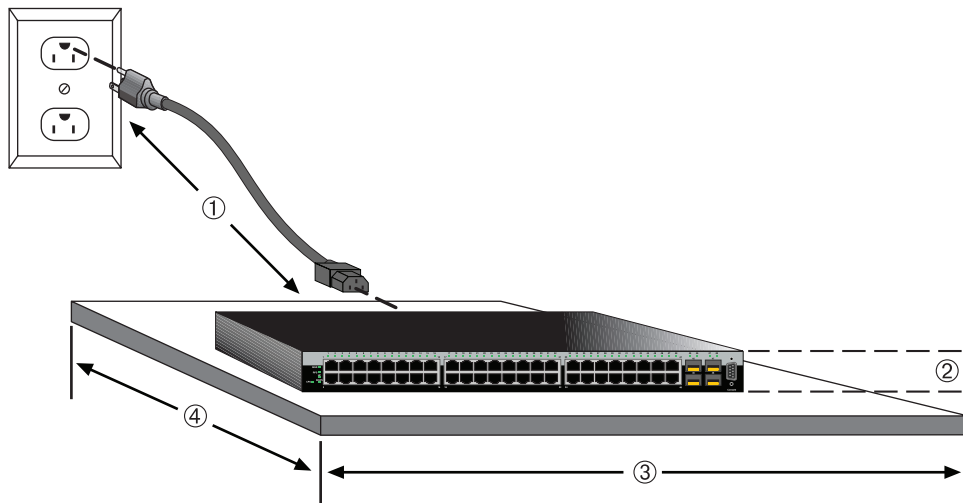

- | | | | |
|---|--|---|--|
| 1 | Approximately 152 cm (5 ft) from power source | 3 | 44.5 cm (17.52 in.) for proper ventilation |
| 2 | 4.45 cm (1.75 in.) per switch. (Vertical clearance depends on number of switches stacked.) | 4 | 41.9 cm (16.5 in.) for proper ventilation |

Rack Mounting the Switch

To install the switch in a 19-inch rack, you need:

- Two rackmount brackets and mounting screws shipped with the switch.
- Four user-supplied screws to attach the switch to a standard 19-inch rack.

Guidelines for Rackmount Installation

The installation site must be within reach of the network cabling and meet the requirements listed below:

- Appropriate grounded power receptacles must be located within 152 cm (5 ft) of the location.
- A temperature of between 0°C (32°F) and 50°C (122°F) must be maintained at the installation site with fluctuations of less than 10°C (18°F) per hour.



Note: To ensure proper ventilation and prevent overheating, leave a minimum clearance space of 5.1 cm (2.0 in.) at the left, right, and rear of the switch.



Warning: Before installing the chassis into a rack, ensure that the rack can support the device(s) without compromising the stability of the rack. Otherwise, personal injury and/or equipment damage may result.

Advertencia: Antes de instalar el chasis en un rack, asegurarse que el rack puede soportar el(los) dispositivo(s) sin comprometer la estabilidad del mismo. De otra forma puede suceder algun tipo de daño personal o del equipo.

Warnhinweis: Schützen Sie sich vor Verletzungen und Geräteschaden, überzeugen Sie sich vor der Installation des Chassis in das Rack, von dessen Stabilität.

Attaching Brackets and Installing in Rack

Proceed as follows to install the switch into a 19-inch rack:

1. Attach the rackmount brackets to the switch, as shown in [Figure 3-5](#), using the eight M3 x 6 mm flathead screws shipped with the switch.

Figure 3-5 Attaching the Rackmount Brackets

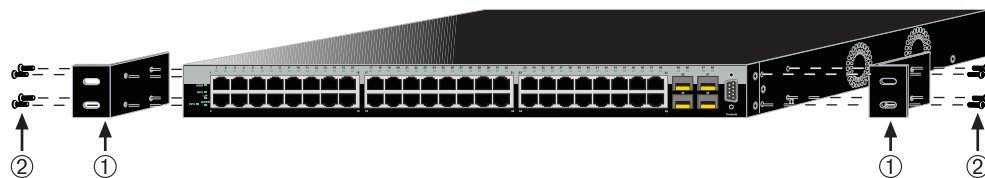

1 Rackmount brackets

2 M3 x 6 mm flathead screws

2. With the mounting brackets attached, position the switch between the vertical frame members of the 19-inch rack as shown in [Figure 3-6](#). Then fasten the switch securely to the frame using four mounting screws (user supplied).

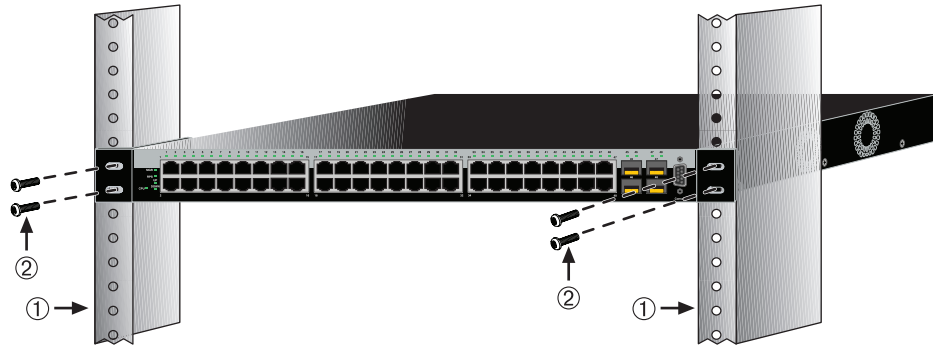
Figure 3-6 Fastening the Switch to the Rack

1 Rails of 19-inch rack

2 Mounting screws (supplied by user)

3. If you are installing this switch in a stacked configuration, repeat this procedure for each switch until all switches have been installed in the stack, then proceed to [“Connecting High-Speed Stacking Cables”](#) on page 3-9. Otherwise, proceed to [“Connecting AC and PoE Power”](#) on page 3-12.

Connecting High-Speed Stacking Cables

The stack of switches can be connected in a ring or daisy chain topology. In a ring topology all the switches are connected. The only difference in the cable connections in a daisy chain topology is that one cable is not installed.

Up to 8 switches can be stacked together using high-speed stacking cables. You can add switches and reach up to a maximum of 384 Ethernet ports per stack. The high-speed stacking cables allow the entire stack to operate with a single IP address.

The high-speed stacking cables are optional items and must be ordered separately. The C3G124-24P and C3G124-48P support three types of stacking cables:

- C2CAB-SHORT cable to connect two adjacent switches in the stack. If the stack is in a configuration where the adjacent switches are too far apart for the SHORT cables, the LONG cable can be used for the connections.
- C2CAB-LONG cable to connect from the top switch to the bottom switch in the stack. You need only one C2CAB-LONG cable per stack.
- C2CAB-5M cable to connect two switches in a stack that are physically located in separate mounting racks and require a longer cable reach.

[Figure 3-7](#) shows an example of a four-high stack connected in a ring topology. All STACK DOWN and STACK UP connectors are used in the installation. The high-speed stacking cable (1) connections are from the STACK DOWN connector (2) of one switch to the STACK UP (3) connector of the next switch up in the stack. A high-speed stacking cable connection from the STACK DOWN (4) connector of the switch at the top of the stack to the STACK UP (5) connector at the bottom of the stack completes the ring connection. In a daisy chain topology, the last cable connection is not made.

Figure 3-7 High-Speed Stacking Cable Connections

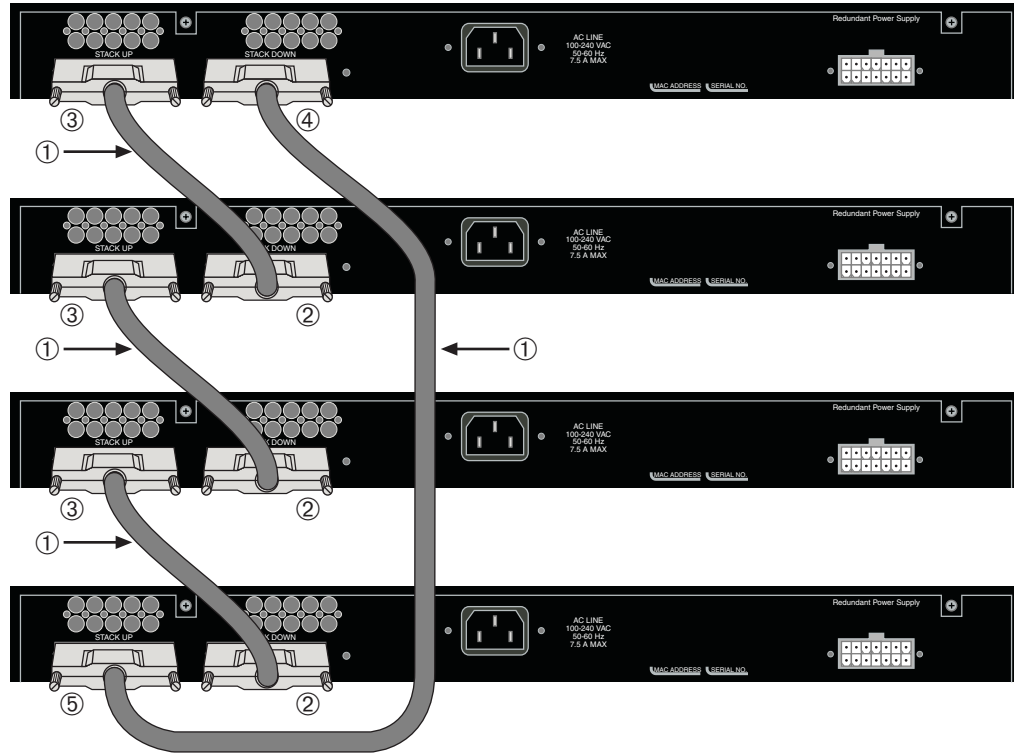

- | | |
|-----------------------------|---|
| 1 High-speed stacking cable | 4 STACK DOWN connector at top of stack |
| 2 STACK DOWN connector | 5 STACK UP connector at bottom of stack |
| 3 STACK UP connector | |

After connecting the cables to the stacking ports, proceed to “[Connecting AC and PoE Power](#)” on page 3-12 for instructions.

Configuring Switches in a Stack

The information in the following sections is important to understand switch operation and installations in a stack installation.

About Switch Operation in a Stack

The products are stackable switches that can be adapted and scaled to help meet your network needs. These switches provide a management platform and uplink to a network backbone for a stacked group of up to eight switches.

Once installed in a stack, the switches behave and perform as a single switch. As such, you can start with a single switch and add more switches as your network expands. You can also mix different products in the family in a single stack to provide a desired combination of port types and functions to match the requirements of individual applications. In all cases, a stack of switches performs as one large product, and is managed as a single network entity.

When switches are installed and connected as described back in “[Connecting High-Speed Stacking Cables](#)” on page 3-9, the following occurs during initialization:

- The switch that will manage the stack is automatically established and is referred to as the Manager switch.

- All other switches are established as Member switches in the stack.
- The hierarchy of the switches that will assume the function of backup manager is also determined in case the current manager malfunctions, is powered down, or is disconnected from the stack.
- The Console port on the manager switch remains active for out-of-band (local) switch management, but the Console port on each member switch is deactivated. This enables you to set the IP address and system password using a single Console port. Now each switch can be configured locally using only the manager's Console port, or in-band using a remote device and the CLI set of commands described in this section. For procedures used for various types of connections to the Console port, refer to "[Connecting to Console Port for Local Management](#)" on page 3-15.

Once a stack is created (more than one switch is interconnected), the following occurs:

1. Switch (unit) IDs are arbitrarily assigned on a first-come, first-served basis.
2. Switch IDs are saved against each module. Then, every time a board is power-cycled, it will initialize with the same switch ID. This is important for port-specific information (for example: ge.4.12 is the 12th Gigabit Ethernet port on switch number 4).
3. The management election process uses the following precedence to assign a management device:
 - a. Previously assigned/elected management switch
 - b. Management assigned priority (values 1–15)
 - c. Hardware preference level
 - d. Highest MAC Address

Recommended Procedures to Install New and Existing Stacks

Important

The following procedures assume that all switches have a clean configuration from manufacturing. When adding a new switch to an already running stack, it is also assumed that the new switch is using the same firmware image version as other switches in the stack.

Installing a New Stackable System of Up to Eight Switches

Use the following procedure to install a new stack of up to eight switches out of the box. Before applying power, make **all** physical connections with the stack cables as described in "[Connecting High-Speed Stacking Cables](#)" on page 3-9.

1. Once all of the stack cables have been connected, individually power on each switch from top to bottom (connecting power to a switch is described in "[Connecting AC and PoE Power](#)" on page 3-12).

If the switches are powered on almost simultaneously, the system will automatically select the first one that powers up as the Master switch and the others as Member switches. The switches are assigned unit IDs in the order that they become fully operational.

You can control the unit ID assignment according to the physical position in a stack. When you power up each switch and allow it to become fully operational before applying power to the next switch, the first one becomes the Manager and all the next switches will join that stack (regardless of Priority, Firmware Revision, or MAC Address). The switches are assigned unit IDs in the order that you power on each switch.



Note: Once switch IDs are assigned, they are persistent and will be retained during a power cycle to any or all of the switches.

2. (Optional) If desired, change the management switch using the **set switch movemanagement** command as described in the *Enterasys C3 Configuration Guide*.
3. Once the desired master switch has been selected, reset the system using the **reset** command as described in the *Enterasys C3 Configuration Guide*.

Adding a New Switch to an Existing Stack

Use the following procedure to install a new switch to an existing stack configuration. This procedure assumes that the new switch being added has a clean configuration from manufacturing and is running the same firmware image version as other switches in the stack.

1. Ensure that power is off on the new switch being installed.
2. Use one of the following methods to complete the stack cable connections:
 - If the running stack uses a daisy chain topology, make the stack cable connections from the bottom of the stack to the new switch (that is, STACK DOWN port from the bottom switch of the running stack to the STACK UP port on the new switch).
 - If the running stack uses a ring stack topology, break the ring and make the stack cable connections to the new switch to close the ring.
3. Apply power to the new switch.

Important Considerations About Using Clear Config in a Stack

When using the **clear config** command (as described in the *Enterasys C3 Configuration Guide*) to clear configuration parameters in a stack, it is important to remember the following:

- Use **clear config** to clear config parameters without clearing stack switch IDs. This command WILL NOT clear stack parameters and avoids the process of re-numbering the stack.
 - Use **clear config all** when it is necessary to clear all config parameters, including stack switch IDs and switch priority values.
-

Connecting AC and PoE Power

AC Power



Note: The power supply in the switch has automatic voltage sensing that allows connection to power sources ranging from 100 to 240 VAC.

To connect the switch to the power source, refer to [Figure 3-8](#) on page 3-13 and proceed as follows:

1. Plug the power cord into the switch AC power connector.
2. Plug the other end of the power cord into a dedicated grounded AC outlet (not shown). The type of power outlet and power cord are country-dependent.



Note: If you plan to connect all the switches quickly to allow automatic Manager selection, wait until all switches are fully operational before proceeding to the next step.

If you plan to power up each switch and allow it to become fully operational before applying power to the next switch, proceed to the next step.

Figure 3-8 Connecting AC Power and RPS

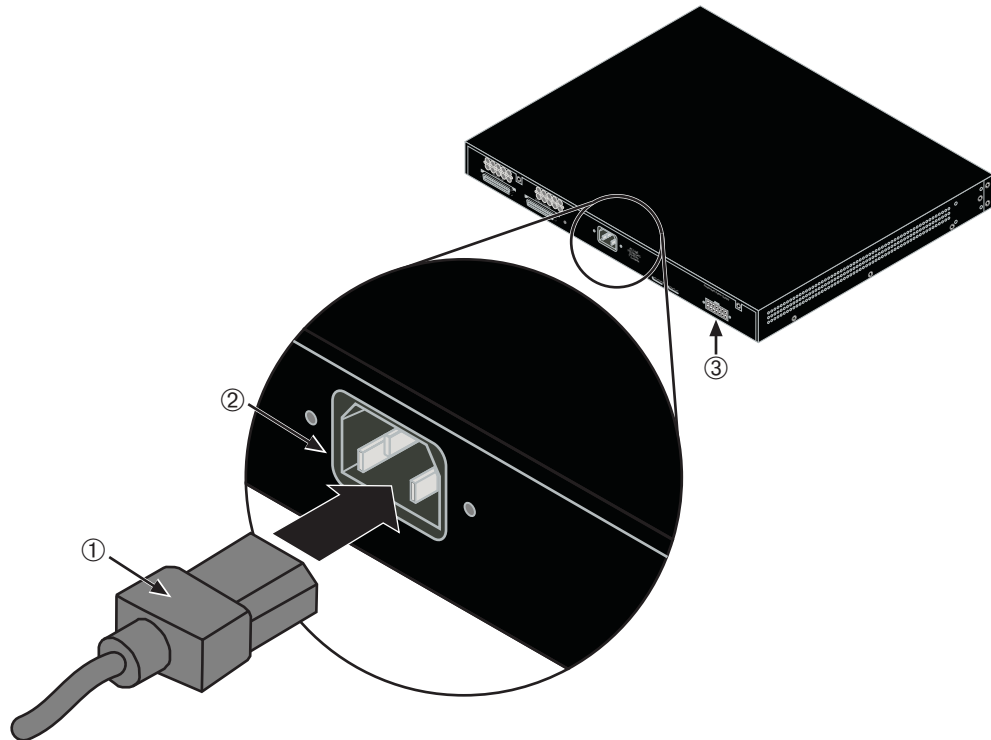

1 AC power cord 2 AC power connector 3 Connector for external redundant power supply

3. Observe the power CPU LED (not shown) located on the front panel. During the initialization, the CPU LED will start by illuminating solid amber, then start blinking green, then blinking amber, then blinking green again until the end of the initialization, and then turns solid green.



Note: If the CPU LED illuminates solid red, there was a critical failure. For more information about the LED indications and troubleshooting, refer to [Chapter 4](#). If you need additional help, contact Enterasys Networks. Refer to “[Getting Help](#)” on page xvi for details.

If the switch is a standalone unit, it will take approximately 30 seconds for the switch to start up. If the switch is a stack Manager, it can take up to 3 minutes or more to start up, depending on the number of Member switches in the stack.

PoE Redundant Power System

If you are connecting an optional PoE redundant power supply (C2RPS-POE), refer to the installation instructions supplied with the C2RPS-POE. The switch is connected to a C2RPS-POE using a C2RPS-POE cable.



Caution: The C2RPS-POE power supply does not support non-PoE compliant switches. Do not try to connect the power cable from this C2RPS-POE power supply to any switch that does not have a “P” suffix in the model name (for example, C3G124-24). Otherwise, damage to the device may result.

Precaución: La fuente de poder C2RPS-POE no es compatible con switches que no cumplan con el estándar PoE. No intente conectar el cable de corriente de esta fuente de poder C2RPS-POE a ningún switch que no tenga el sufijo “P” en el nombre del modelo (por ejemplo, C3G124-24). De lo contrario, el dispositivo puede dañarse.

If you are installing the switch as a standalone device, proceed to [“Connecting to Console Port for Local Management”](#) on page 3-15. If you are installing switches in a stack configuration, proceed to [“Stack Manager Selection”](#) on page 3-14.

Stack Manager Selection

When you install and connect all the high-speed stacking cables to the switches in the stack before applying power to the switches, the following occurs:

- The switch that will manage (Manager) the stack is automatically established with all other switches established as Member switches in the stack. When the switches complete their initializations, one of the switches in the stack will illuminate its Manager LED, indicating that it is the stack Manager. The Manager LED on each Member switch will be off.
- The hierarchy of the switches that will function as backup Manager is also determined in case the current Manager malfunctions, is powered down, or is disconnected from the stack.
- The Console port on each Member switch is deactivated. Only the Console port on the Manager switch is active for out-of band configuration to set the IP address, password, and other configuration settings.

Once you know which switch is the Manager, proceed to [“Connecting to Console Port for Local Management”](#) on page 3-15.

Connecting to Console Port for Local Management

This section describes how to install an RS232 DTE interface cable to a PC, a VT series terminal, or a modem to a C3G124-24P or C3G124-48P for out-of-band sessions using CLI commands.



Note: When switches are connected in a stack configuration and all high-speed stacking cables are connected before powering up the switches, one switch in the stack will be automatically designated as the Manager of the stack and its Console port will remain active. All other switches will become Member switches and their Console ports will be deactivated.

What Is Needed

The following is a list of DTE interface cables that may be needed to connect the DB9 male Console port connector on the switch. The cables are terminated by a DB9 female connector at one end, and by one of three type connectors at the other end, depending on the type connection needed for the remote device. The cables that may be needed are as follows:

- DB9 female-to-DB9 female (supplied with switch)
- DB9 female-to-DB25 female
- DB9 female-to-DB25 male

Using a DTE modem DB9 female-to-DB9 female cable, you can connect products equipped with a DB9 DTE male console port to an IBM or compatible PC running a VT series emulation software package.

Using a DTE modem DB9 female-to-DB25 female cable, you can connect products equipped with a DB9 DTE male console port to a VT series terminal or VT type terminals running emulation programs for the VT series.

Using a DTE modem DB9 female-to-DB25 male cable, you can connect products equipped with a DB9 DTE male console port to a Hayes compatible modem that supports 9600 baud.

The cable used must connect the Console port Received Data, Pin 2 to the Transmitted Data pin at the other end of the cable. The connection from the Console port Transmitted Data, Pin 3 (must be connected) to the Received Data pin cable connection at the other end of the cable. The DB9 Console port pin assignments are shown in [Figure 3-9](#).

Figure 3-9 DB9 Male Console Port Pinout Assignments

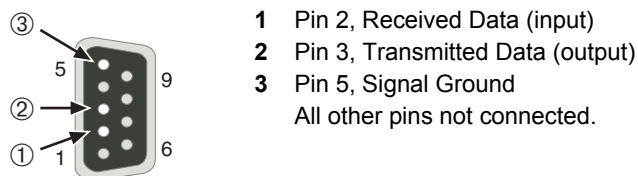

Connecting to an IBM or Compatible Device

To connect an IBM PC or compatible device, running the VT terminal emulation, to a switch Console port (Figure 3-10), proceed as follows:

1. Connect the DB9 female connector at one end of the cable (not supplied) to the Console port on the switch. (If there is a switch designated as the Manager, connect to its Console port.)
2. Plug the DB9 female connector at the other end of cable into the communications port on the PC.
3. Turn on the PC and configure your VT emulation package with the following parameters:

Parameter	Setting
Mode	7 Bit Control
Transmit	Transmit=9600
Bits Parity	8 Bits, No Parity
Stop Bit	1 Stop Bit

When these parameters are set, the Startup screen will display. Proceed to “[Connecting to the Network](#)” on page 3-19.

Figure 3-10 Connecting an IBM PC or Compatible

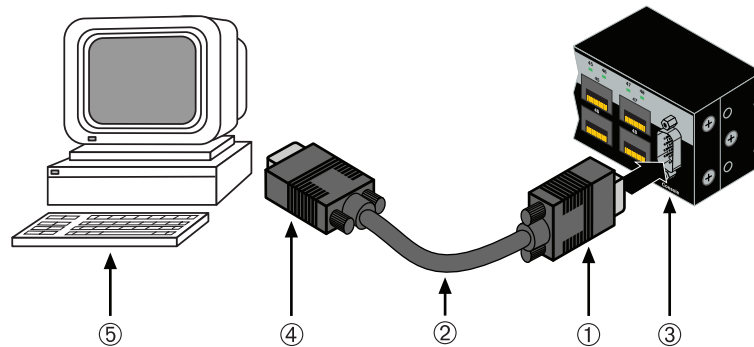

- | | |
|-----------------------------------|------------------------------------|
| 1 DB9 female cable connector | 4 DB9 female connector |
| 2 Serial interface cable | 5 PC with VT emulation application |
| 3 DB9 male Console port connector | |

Connecting to a VT Series Terminal

To connect a VT Series terminal to a switch Console port (Figure 3-11), use a UTP serial interface cable terminated with a DB9 female connector and a DB25 female connector and proceed as follows:

1. Connect the DB9 female connector at one end of cable to the DB9 male Console port connector on the switch. (If there is a switch designated as the Manager, connect to its Console port.)
2. Plug the DB25 female connector at the other end of the cable into the port labeled COMM on the VT terminal.
3. Turn on the terminal and access the Setup Directory. Set the following parameters on your terminal:

Parameter	Setting
Mode	7 Bit Control
Transmit	Transmit=9600
Bits Parity	8 Bits, No Parity
Stop Bit	1 Stop Bit

When these parameters are set, the Startup screen will display. Proceed to [“Connecting to the Network”](#) on page 3-19.

Figure 3-11 Connecting a VT Series Terminal

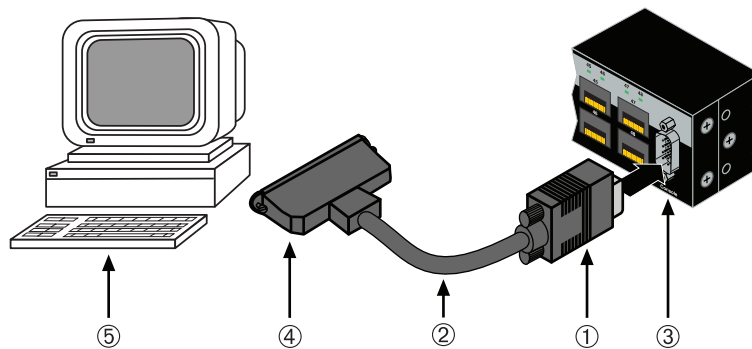

- | | |
|-----------------------------------|------------------------------------|
| 1 DB9 female cable connector | 4 DB25 female connector |
| 2 Serial interface cable | 5 PC with VT emulation application |
| 3 DB9 male Console port connector | |

Connecting to a Modem

To connect a modem to a switch modem port (Figure 3-12), use a UTP cable terminated with a DB9 female connector and a DB25 male connector, and proceed as follows:

1. Connect the DB9 female connector at one end of the cable to the DB9 male Console port connector on the switch. (If there is a switch designated as the Manager, connect to its Console port.)
2. Plug the DB25 male connector at the other end of the cable into the modem communications port.
3. Turn on the modem and make sure the remote modem is ON.
4. With your PC connected to the remote modem, configure your VT emulation package with the following parameters:

Parameter	Setting
Mode	7 Bit Control
Transmit	Transmit=9600
Bits Parity	8 Bits, No Parity
Stop Bit	1 Stop Bit

When these parameters are set, the Startup screen will display. If the switches are in a stacked configuration, proceed to [“Connecting to the Network”](#) on page 3-19.

Figure 3-12 Connecting to a Modem

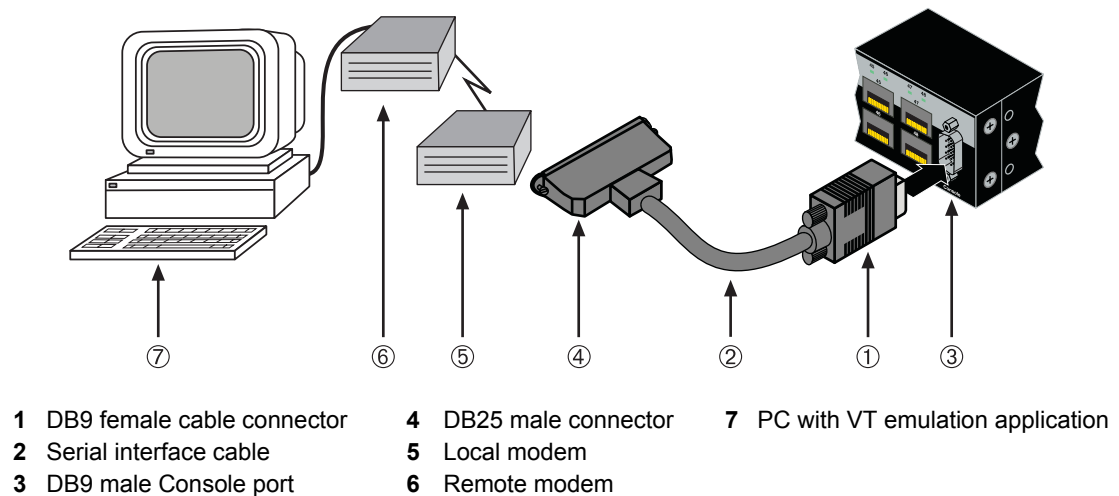

Connecting to the Network

The following procedures cover the cable connections from the network or other devices to the switch RJ45 ports or any installed optional Mini-GBIC.

- [Connecting UTP Cables](#) on page 3-19
- [Connecting Fiber-Optic Cables to MT-RJ Ports](#) on page 3-20
- [Connecting Fiber-Optic Cables to LC Ports](#) on page 3-22

Connecting UTP Cables

The fixed RJ45 front panel ports are 10/100/1000 Mbps ports and have internal crossovers. When connecting a workstation to these ports, use a straight-through cable. When connecting networking devices to these ports, such as a bridge, repeater, or router, use a crossover cable.



Note: All fixed RJ45 front panel ports support Category 5 Unshielded Twisted Pair (UTP) cabling with an impedance between 85 and 111 ohms. Category 3 cable may be used if the connection is going to be used only for 10 Mbps.

To connect twisted pair segments to the switch, refer to [Figure 3-13](#) and proceed as follows:

1. Ensure that the device to be connected at the other end of the segment is powered ON.
2. Connect the twisted pair segment to the switch by inserting the RJ45 connector on the twisted pair segment into the desired RJ45 port (for example, Port 8).

Figure 3-13 Connecting a UTP Cable Segment to RJ45 Port

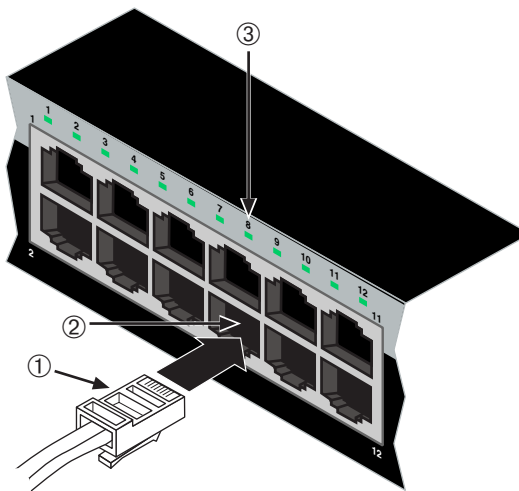

1 RJ45 connector

2 Port 8

3 Port 8 Link/Activity LED

3. Verify that a link exists by checking that the Link/Activity LED is ON (solid green or blinking green).



Note: If the cable is connected to one of the PoE RJ45 front panel ports, solid green or blinking green also indicates that PoE power is available. If the LED is solid amber or blinking amber PoE power failed. For more details, refer to [Chapter 4](#).

4. If the Link/Activity LED is OFF, perform the following steps until it is on:
 - a. Verify that the cabling being used is Category 5 or better with an impedance between 85 and 111 ohms with a maximum length of 100 meters (328 feet).
 - b. Verify that the device at the other end of the twisted pair segment is on and properly connected to the segment.
 - c. Verify that the RJ45 connectors on the twisted pair segment have the proper pinouts and check the cable for continuity.

If a link is not established or there is no PoE power, contact Enterasys Networks. Refer to [“Getting Help”](#) on page xvi for details.

Repeat all steps above until all connections have been made.

Connecting Fiber-Optic Cables to MT-RJ Ports



Warning: Do not use optical instruments to view laser output. The use of optical instruments to view laser output increases eye hazard.

Advertencia: No utilizar instrumentos opticos para ver el laser. El uso de instrumentos opticos para ver el laser incrementa el riesgo de perdida de la vision.

Warnhinweis: Benutzen sie keinesfalls optische Hilfsmittel, um die Funktion des Lasers zu überprüfen, es könnte ihr Augenlicht gefährden.

This section contains the procedures for connecting a 1000BASE-SX multimode fiber-optic segment from the network or other devices to an MT-RJ port connector in a Mini-GBIC (MGBIC-MT01).

Each fiber-optic link consists of two fiber-optic strands within the cable:

- Transmit (TX)
- Receive (RX)

The transmit strand from a device port connects to the receive port of a fiber-optic Gigabit Ethernet device at the other end of the segment. The receive strand of the applicable MT-RJ port connects to the transmit port of the fiber-optic Gigabit Ethernet device.

Enterasys Networks recommends labeling fiber-optic cables to indicate receive and transmit ends. Many cables are pre-labeled, providing matching labels or tapes at both ends of each strand of cable.

To connect an MT-RJ cable to a fixed MT-RJ connector of a Mini-GBIC, refer to [Figure 3-14](#) on page 3-21 and proceed as follows:

1. Remove the protective covers (not shown) from the front panel MT-RJ fiber-optic port (port 46 in this example) and from the connectors on each end of the cable.

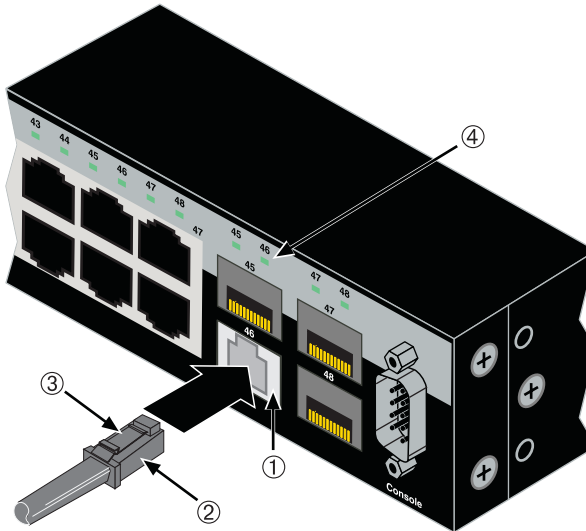
Figure 3-14 Cable Connection to MT-RJ Multimode Fiber-Optic Connectors

- | | |
|----------------------------------|---------------------|
| 1 Mini-GBIC MT-RJ port connector | 3 Release tab |
| 2 MT-RJ cable connector | 4 Link/Activity LED |



Note: Leave the protective covers in place when the connectors are not in use to prevent contamination.



Caution: Do not touch the ends of the fiber-optic strands, and do not let the ends come in contact with dust, dirt, or other contaminants. Contamination of cable ends causes problems in data transmissions. If the ends of the fiber-optic strands become contaminated, use a canned duster to blow the surfaces clean. A fiber-port cleaning swab saturated with optical-grade isopropyl alcohol may also be used to clean the ends.

Precaución: No toque los extremos de los cables de fibra óptica y evite su contacto con el polvo, la suciedad o con cualquier otro contaminante. Si los extremos de los cables se ensucian, es posible que la transmisión de datos se vea afectada. Si nota que los extremos de los cables de fibra óptica se ensucian, utilice aire comprimido para limpiarlos. También puede limpiarlos con un estropajo embebido en alcohol isopropílico.

- Insert the MT-RJ cable connector into the MT-RJ connector until it clicks into place.



Note: To remove the MT-RJ cable connector, press on its release tab and pull out the cable connector.

- Plug the other end of the cable into the appropriate port on the other device. Some cables may be terminated at the other end with two separate connectors, one for each fiber-optic strand. In this case, ensure that the transmit fiber-optic strand is connected to the receive port and the receive fiber-optic strand to the transmit port.
- Verify that a link exists by checking that the port Link/Activity LED is on (blinking green or solid green). If the Link/Activity LED is off, perform the following steps until it is on:
 - Verify that the device at the other end of the segment is ON and connected to the segment.
 - If there are separate fiber-optic connections on the other device, check the crossover of the cables. Swap the cable connections if necessary.

If a link has not been established, refer to [Chapter 4](#) for LED troubleshooting details. If a problem persists, refer to “[Getting Help](#)” on page xvi for details on contacting Enterasys Networks for support.

- Repeat steps 1 through 4, above, until all connections have been made.

Connecting Fiber-Optic Cables to LC Ports



Warning: Do not use optical instruments to view laser output. The use of optical instruments to view laser output increases eye hazard.

Advertencia: No utilizar instrumentos ópticos para ver el laser. El uso de instrumentos ópticos para ver el laser incrementa el riesgo de pérdida de la visión.

Warnhinweis: Benutzen sie keinesfalls optische Hilfsmittel, um die Funktion des Lasers zu überprüfen, es könnte ihr Augenlicht gefährden.

This section describes how to connect

- a 1000BASE-SX multimode fiber-optic segment from the network or other devices to an LC port connector of a Mini-GBIC (MGBIC-LC01 or MGBIC-LC03), or
- a 1000BASE-LX single-mode fiber-optic segment from the network or other devices to an LC port connector of a Mini-GBIC (MGBIC-LC09).

Each fiber-optic link consists of two fiber-optic strands within the cable:

- Transmit (TX)
- Receive (RX)

The transmit strand from a device port connects to the receive port of a fiber-optic Gigabit Ethernet device at the other end of the segment. The receive strand of the applicable LC port connects to the transmit port of the fiber-optic Gigabit Ethernet device.

Enterasys recommends labeling fiber-optic cables to indicate receive and transmit ends. Many cables are pre-labeled, providing matching labels or tapes at both ends of each strand of cable.

To connect an LC cable connector to a fixed LC connector of a Mini-GBIC, refer to [Figure 3-15](#) on page 3-23 and proceed as follows:



Caution: Do not touch the ends of the fiber-optic strands, and do not let the ends come in contact with dust, dirt, or other contaminants. Contamination of cable ends causes problems in data transmissions. If the ends of the fiber-optic strands become contaminated, use a canned duster to blow the surfaces clean. A fiber-port cleaning swab saturated with optical-grade isopropyl alcohol may also be used to clean the ends.

Precaución: No toque los extremos de los cables de fibra óptica y evite su contacto con el polvo, la suciedad o con cualquier otro contaminante. Si los extremos de los cables se ensucian, es posible que la transmisión de datos se vea afectada. Si nota que los extremos de los cables de fibra óptica se ensucian, utilice aire comprimido para limpiarlos. También puede limpiarlos con un estropajo embebido en alcohol isopropílico.

- Remove the protective covers (not shown) from the front panel LC fiber-optic port (port 46 in this example) and from the connectors on each end of the cable.



Note: Leave the protective covers in place when the connectors are not in use to prevent contamination.

- Insert the LC cable connector into the Mini-GBIC LC connector until it clicks into place.



Note: To remove the LC cable connector, press on its release tab and pull it out of Mini-GBIC LC connector.

Figure 3-15 Cable Connection to LC Fiber-Optic Connectors

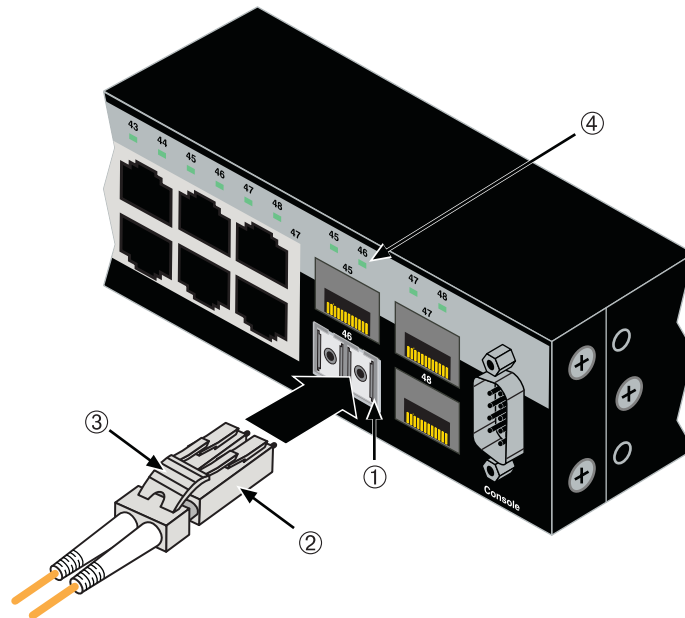

- 1 Mini-GBIC MT-RJ port connector
- 2 LC cable connector

- 3 Release tab
- 4 Link/Activity LED

3. Plug the other end of the cable into the appropriate port on the other device. Some cables may be terminated at the other end with two separate connectors, one for each fiber-optic strand. In this case, ensure that the transmit fiber-optic strand is connected to the receive port and the receive fiber-optic strand to the transmit port.
4. Verify that a link exists by checking that the port Link/Activity LED is on (blinking green or solid green). If the Link/Activity LED is off, perform the following steps until it is on:
 - a. Verify that the device at the other end of the segment is ON and connected to the segment.
 - b. If there are separate fiber-optic connections on the other device, check the crossover of the cables. Swap the cable connections if necessary.
 - c. If a link has not been established, refer to [Chapter 4](#) for LED troubleshooting details. If a problem persists, refer to “[Getting Help](#)” on page xvi for details on contacting Enterasys Networks for support.
5. Repeat steps 1 through 4, above, until all connections have been made.

Completing the Installation

After installing the switch and making the connections to the network, access the switch management, as described below.

Initial Logon to Switch Management

To initially access switch management from your local PC, terminal, or modem connection, proceed as follows at the displayed startup screen:

1. Enter **rw** (Read-Write) for Username.
2. At the Password prompt, press **Enter** (Return).
3. For details on how to configure the switch using the command line interface, refer to the *Enterasys C3 Configuration Guide*. The CLI commands enable you to set a new password and perform more involved management configurations on the switch. One of many capabilities is to reconfigure the stack, reassigning the Manager function to another switch and configuring the order of Member switches that will take over the stack management functions in case the operating Manager is powered down, malfunctions, or is removed from the stack.
4. After the initial configuration, you can also use WebView (Enterasys Networks' embedded web server) for configuration and management tasks.

All the guides associated with the switch are available online at:
<http://www.enterasys.com/support/manuals>

Once you are confident that the installation is successful, route and secure your cables. If you require assistance, contact Enterasys Networks using one of the methods described in “[Getting Help](#)” on page xvi.

4

Troubleshooting

This chapter provides information concerning the following:

For information about...	Refer to page...
Using LANVIEW	4-2
Troubleshooting Checklist	4-6
Using the Reset Switch	4-7

This device contains a battery that is not considered a user replaceable part. If the battery needs to be replaced, contact customer service for repair.



Caution: There is a risk of explosion if the battery is replaced with an incorrect type. A used battery may be safely disposed in a municipal waste stream.

Precaucion: Hay riesgo de explosion si la bateria se reemplaza con el typo incorrecto. Puede tirar la bateria usada en la basura

Using LANVIEW

The switch uses the Enterasys Networks built-in visual diagnostic and status monitoring system called LANVIEW. For the location of LANVIEW LEDs on the C3G124-24P and C3G124-48P, refer to [Figure 4-1](#) and [Figure 4-2](#), respectively. These LEDs allow you to quickly observe network status for diagnosing switch and network problems.

Figure 4-1 C3G124-24P LANVIEW LEDs

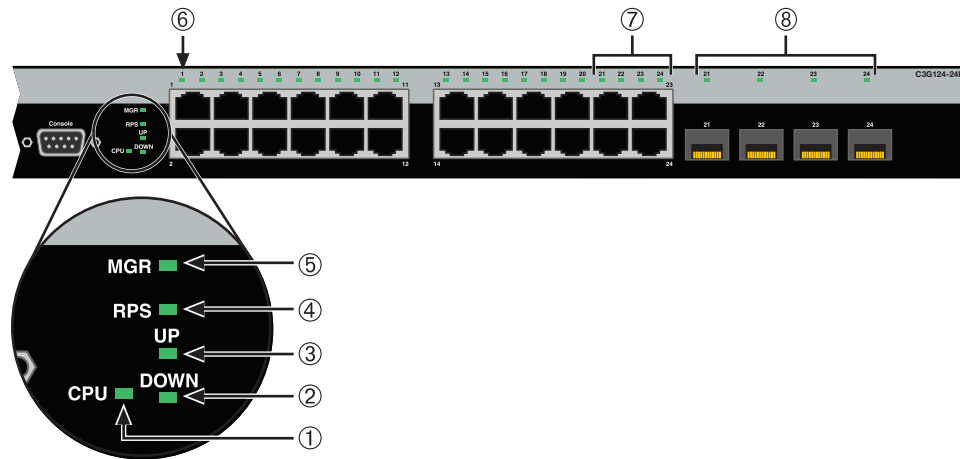

- | | |
|---|--|
| 1 CPU LED | 6 Link/Activity/PoE LED for 10/100/1000 Mbps, RJ45 port 1 |
| 2 STACK DOWN LED | 7 Link/Activity/PoE LEDs for 10/100/1000 Mbps RJ45 ports 21 through 24 |
| 3 STACK UP LED | 8 Link/Activity LEDs for 1-Gbps Mini-GBIC ports 21 through 24 ¹ |
| 4 RPS LED for redundant power source status | |
| 5 Manager LED | |

1. These Mini-GBIC ports will only establish a link when the RJ45 port equivalent is not linked on a C3G124-24P. (For example, when Mini-GBIC port 24 is linked, RJ45 port 24 is deactivated. When the Mini-GBIC is not linked, the RJ45 port 24 is reactivated and can establish a link as long as the Mini-GBIC port 24 is not linked first.)

Figure 4-2 C3G124-48P LANVIEW LEDs

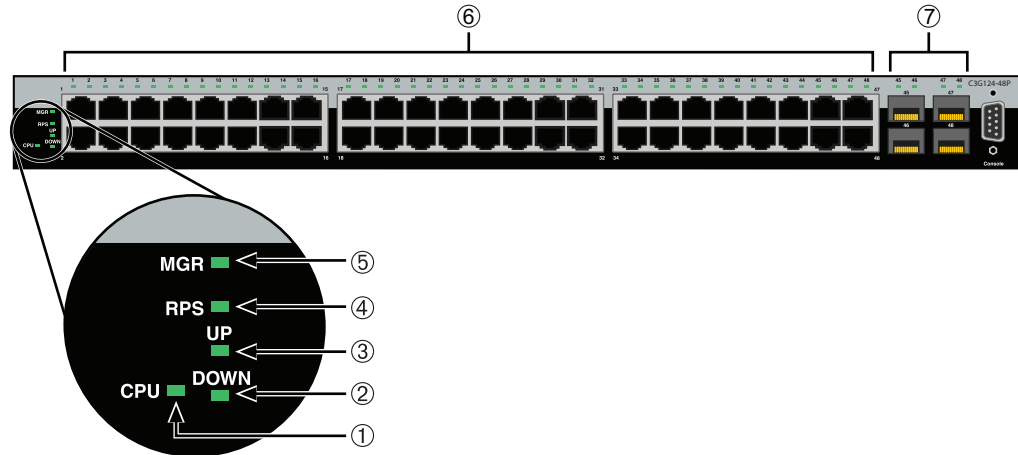

- | | |
|---|--|
| 1 CPU LED | 5 Manager LED |
| 2 STACK DOWN LED | 6 Link/Activity LEDs for 10/100/1000 Mbps RJ45 ports 1 through 48 |
| 3 STACK UP LED | 7 Link/Activity LEDs for 1-Gbps Mini-GBIC ports 45 through 48 ¹ |
| 4 RPS LED for redundant power-source status | |

1. These Mini-GBIC ports will only establish a link when the RJ45 port equivalent is not linked on a C3G124-48P. (For example, when Mini-GBIC port 45 is linked, RJ45 port 45 is deactivated. When the Mini-GBIC is not linked, the RJ45 port 45 is reactivated and can establish a link as long as the Mini-GBIC port 45 is not linked first.)

Table 4-1 describes the LED indications and provides recommended actions as appropriate.



Note: The terms **flashing**, **blinking**, and **solid** used in Table 4-1 indicate the following:

Flashing: LED is flashing randomly.

Blinking: LED is flashing at a steady rate (approximately 50% on, 50% off).

Solid: LED is on steady and not pulsing.

Table 4-1 LANVIEW LED Diagnostic Indications

LED	Color	State	Recommended Action
CPU	Off	Power disconnected.	If the LED remains off after connecting AC power or DC power from an RPS, check the following: <ol style="list-style-type: none"> 1. Make sure there is power at the power source (AC source and RPS if applicable). 2. Replace the power cord with a known good one or check the continuity of the power cord. 3. If the switch still does not power up, the system may have a fatal error. Contact Enterasys Networks for technical support.
	Red	Solid. Boot-up failed.	If the LED remains red for several minutes, the system may have a fatal error. Contact Enterasys Networks for technical support.
	Amber	Solid. Diagnostics are running.	If the LED remains amber for more than several minutes, contact Enterasys Networks for technical support.
		Blinking. Code image is being downloaded.	None.
	Green	Solid. System is fully functional.	None.
Blinking. Boot-up in process.		None.	
DOWN	Off	No valid connection to switch stack up connector.	<ol style="list-style-type: none"> 1. Make sure the switch connected to the stack up connector is powered on. 2. Replace cable with a known good one. 3. If the problem still exists, contact Enterasys Networks for technical support.
	Green	Solid. Valid connection to switch stack up connector. Blinking. Information is being transferred through the high-speed stacking cable.	None.
UP	Off	No valid connection to switch stack down connector.	<ol style="list-style-type: none"> 1. Make sure the switch connected to the stack down connector is powered on. 2. Replace cable with a known good one. 3. If the problem still exists, contact Enterasys Networks for technical support.
	Green	Solid. Valid connection to switch stack down connector. Blinking. Information is being transferred through the high-speed stacking cable.	None.
Manager	Off	Switch is operating as a Member in the stack.	None.
	Green	Solid. Switch is operating as the Manager of the stack.	None.

Table 4-1 LANVIEW LED Diagnostic Indications (continued)

LED	Color	State	Recommended Action
RPS	Off	Connected C2RPS-POE supply not in use. Internal power supply failed.	None. If a C2RPS-POE RPS is connected to the switch, it should be providing power. To determine if there is a problem, perform the following: <ol style="list-style-type: none"> 1. Ensure the RPS is powered on. 2. Ensure that the AC power cord to the RPS is plugged in correctly and that there is power at the AC power source. 3. Replace the power cord with a known good one. 4. Ensure the DC power cable (C2RPS-POE) from the RPS to the switch is plugged in correctly. 5. If the problem persists, contact Enterasys Networks for technical support.
	Amber	Solid. The switch internal power supply failed, and the RPS is providing the proper power to the switch.	None.
Link/ Activity (RJ45 PoE ports)	Off	1. No link.	None.
		2. No activity or port in standby.	None.
		3. The port is deactivated because the Mini-GBIC port with the same port number is linked.	None.
	Green	Solid. Port is linked, but the interface is not receiving any traffic. PoE power is available.	None.
		Blinking. Port is linked and traffic is being received or transmitted by the interface. PoE power is available.	None.
	Amber	Solid. Port is linked, but traffic is not being received or transmitted by the interface. PoE power has failed. PoE power may have been deactivated because of excessive power requirement or deactivated by configuration. Power Supply failed.	<ol style="list-style-type: none"> 1. Check the attached powered device to see if it is defective. 2. Internal power supply failed, contact Enterasys Networks for technical support.
Blinking. Port is linked and traffic is being received or transmitted by the interface. PoE power has failed. PoE power may have been deactivated because of excessive power requirement or deactivated by configuration. Power supply failed.		<ol style="list-style-type: none"> 1. Check the attached powered device to see if it is defective. 2. Internal power supply failed, contact Enterasys Networks for technical support. 	

Table 4-1 LANVIEW LED Diagnostic Indications (continued)

LED	Color	State	Recommended Action
Link/ Activity (MGBIC ports)	Off	1. No link.	None.
		2. No activity or port in standby.	None.
	Green	Solid. Port is linked, but the interface is not receiving any traffic.	None.
		Blinking. Port is linked and traffic is being received or transmitted by the interface.	None.

Troubleshooting Checklist

If the device is not working properly, refer to [Table 4-2](#) for a checklist of problems, possible causes, and recommended actions to resolve the problem.

Table 4-2 Troubleshooting Checklist

Problem	Possible Cause	Recommended Action
All LEDs are OFF.	Loss of power.	<p>Ensure that the switch was installed properly according to the installation instructions in Chapter 3.</p> <p>Ensure that the power cords are connected properly to an active power source that meets the AC input specifications for this switch.</p> <p>Ensure that the AC power cord is not damaged. Replace the power cord with a known good one.</p>
No local management startup screen.	Incorrect terminal setup.	Refer to the <i>Enterasys C3 Configuration Guide</i> for proper setup procedures.
	Improper Console cable pinouts.	Refer to Appendix A for proper Console port pinouts.
	Corrupt firmware image, or hardware fault.	If possible, attempt to download the image to the device again. Refer to the <i>Enterasys C3 Configuration Guide</i> for details.
Cannot navigate beyond startup screen.	Improper Community Names Table.	Refer to the <i>Enterasys C3 Configuration Guide</i> for the Community Names Table setup.
Cannot contact the switch through in-band management.	IP address not assigned.	Refer to the <i>Enterasys C3 Configuration Guide</i> for the IP address assignment procedure.
	Port is disabled.	<p>This is normal if the switch is a Member in a stack.</p> <p>If operating as a standalone switch or as the Manager in a stack, enable the port. Refer to the <i>Enterasys C3 Configuration Guide</i> for instructions to enable/disable ports.</p>
	No link to device.	<p>Verify that all network connections between the network management station and the device are valid and operating.</p> <p>If the problem continues, contact Enterasys Networks for technical support.</p>

Table 4-2 Troubleshooting Checklist (continued)

Problem	Possible Cause	Recommended Action
Port(s) goes into standby for no apparent reason.	Loop condition detected.	Verify that Spanning Tree is enabled. Refer to the <i>Enterasys C3 Configuration Guide</i> for the instructions to set the type of STA. Review the network design and delete unnecessary loops. If the problem continues, contact Enterasys Networks for technical support.
User parameters (IP address, device and module name, etc.) were lost when the switch power was cycled.	Clear NVRAM was set using CLI commands.	Reenter the lost parameters as necessary. Refer to the <i>Enterasys C3 Configuration Guide</i> for the instructions to configure the switch using CLI commands. If the problem continues, contact Enterasys Networks for technical support.

Using the Reset Switch

If you forget the switch login password, use the Reset switch to reset the login password to the default password, as described in the following procedure.

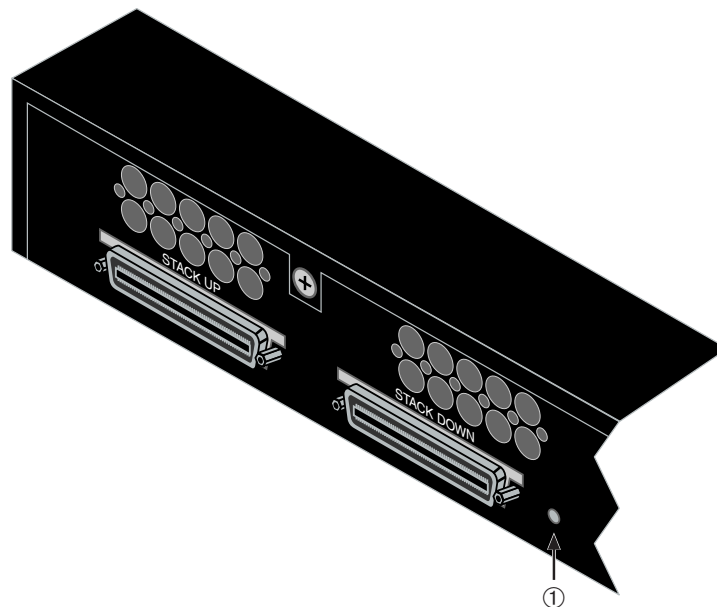
Figure 4-3 Reset Switch

1 Reset switch

To reset the switch password, refer to [Figure 4-3](#) and proceed as follows:



Note: Notify the system manager before changing the password.

1. Press-and-hold the Reset switch while the switch device is operational. This change of the login password to the default password will be indicated through CLI only.
2. Logon to device management. You can now logon to the switch through the Console port and assign a new password using the command line interface (CLI).

3. To access switch management from your local PC, terminal, or modem connection, refer to the *Enterasys C3 Configuration Guide* for instructions on how to log in and enter a new password. The guide is available at:

<http://www.enterasys.com/support/manuals>

If you require assistance, contact Enterasys Networks using one of the methods described in “[Getting Help](#)” on page xvi.



Specifications

This appendix provides information about the following:

For information about...	Refer to page...
Switch Specifications	A-1
Mini-GBIC Compatibility and Specifications	A-3
Console Port Pinout Assignments	A-3
Regulatory Compliance	A-4

Enterasys Networks reserves the right to change the specifications at any time without notice.

Switch Specifications

[Table A-1](#) provides the I/O ports, processors and memory, physical, and environmental specifications for the C3G124-24P and C3G124-48P.

Table A-1 C3G124-24P and C3G124-48P Specifications

Item	Specification
C3G124-24P	
RJ45 ports 1 through 24	Twenty-four, 10BASE-T/100BASE-TX/1000BASE-T compliant ports with auto-sensing and auto-negotiation via RJ45 connectors. These ports also support 802.3af PoE connections.
SFP ports 21 through 24	Four slots that support optional Mini-GBICs 1000BASE-FX fiber-optic connections and 1000BASE-T copper connections. When an SFP transceiver (Mini-GBIC) installed in ports 21 through 24 establishes a link, the associated fixed front panel RJ45 10BASE-T/100BASE-TX/1000BASE-T port is disabled.

Table A-1 C3G124-24P and C3G124-48P Specifications (continued)

Item	Specification
C3G124-48P	
RJ45 ports 1 through 48	Forty-eight, 10BASE-T/100BASE-TX/1000BASE-T compliant ports with auto-sensing and auto-negotiation via RJ45 connectors. These ports also support 802.3af PoE connections.
SFP ports 45 through 48	Four slots that support optional Mini-GBICs for 1000BASE-FX fiber-optic connections and 1000BASE-T copper connections. When an SFP transceiver (Mini-GBIC) installed in ports 45 through 48 establishes a link, the associated fixed front panel RJ45 10BASE-T/100BASE-TX/1000BASE-T port is disabled.
Processors/Memory	
Processor	MPC8245, 400 MHz processor
Dynamic Random Access Memory (DRAM)	256 MB
FLASH Memory	32 MB
Physical	
Dimensions	4.4 H x 44.1 W x 36.85 D (cm) 1.7 H x 17.4 W x 14.5 D (in.)
Approximate Weight	
C3G124-24P	Gross: 8.43 kg (18.59 lb) (shipping carton containing one module) Net: 6.25 kg (13.78 lb) (one module without packaging)
C3G124-48P	Gross: 8.73 kg (19.25 lb) (shipping carton containing one module) Net: 6.55 kg (14.44 lb) (one module without packaging)
Predicted hours for Mean Time Between Failures (MTBF)	Information about MTBF is located at http://www.enterasys.com/support/mtbf
Power Consumption (maximum)	
C3G124-24P	530 W
C3G124-48P	570 W

Table A-1 C3G124-24P and C3G124-48P Specifications (continued)

Item	Specification
AC Input Specifications	
Input Voltage	100 to 240 VAC
Input Current	
C3G124-24P	7.5 A Max
C3G124-48P	7.5 A Max
Frequency	50 to 60 Hz
Environmental	
Operating Temperature	0°C to 50°C (32°F to 122°F)
Storage Temperature	-40°C to 70°C (-40°F to 158°F)
Operating Relative Humidity	5% to 95% (non-condensing)

Mini-GBIC Compatibility and Specifications

For Mini-GBIC transceiver compatibility and specifications, refer to the datasheet at <http://www.enterasys.com/products/transceivers-ds.pdf>.

Console Port Pinout Assignments

The Console port is a DB9 serial communications port for local access to Local Management. Refer to [Figure A-1](#) for the Console port pin assignments.

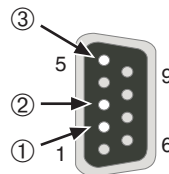
Figure A-1 Console Port Pinout Assignments

- | | |
|---|-------------------------------|
| 1 Pin 2, Received Data (input) | 3 Pin 5, Signal Ground |
| 2 Pin 3, Transmitted Data (output) | All other pins not connected. |

Regulatory Compliance

This C3G124-24P and C3G124-48P meet the safety, electromagnetic compatibility (EMC), and environmental requirements listed in [Table A-2](#):

Table A-2 Compliance Standards

Regulatory Compliance	Standard
Safety	UL 60950-1, FDA 21 CFR 1040.10 and 1040.11, CAN/CSA C22.2 No. 60950-1, EN 60950-1, EN 60825-1, EN 60825-2, IEC 60950-1, 2006/95/EC (Low Voltage Directive)
Electromagnetic Compatibility (EMC)	FCC 47 CFR Part 15 (Class A), ICES-003 (Class A), EN 55022 (Class A), EN 55024, EN 61000-3-2, EN 61000-3-3, AS/NZ CISPR-22 (Class A). VCCI V-3. CNS 13438 (BSMI), 2004/108/EC (EMC Directive)
Environmental	2002/95/EC (RoHS Directive), 2002/96/EC (WEEE Directive), Ministry of Information Order #39 (China RoHS)

Numerics

- 1000BASE-FX network connections
 - requirements for [2-2](#)
- 1000BASE-T
 - requirements for [2-2](#)
- 100BASE-T
 - requirements [2-2](#)
- 10BASE-T
 - connection [3-19](#)
 - requirements [2-1](#)

A

- AC input specifications
 - specifications
 - AC input [A-3](#)
- AC power
 - connecting to [3-12](#)

C

- C3G124-24P stackable switch
 - introduction to [1-1](#)
- C3G124-48P stackable switch
 - introduction to [1-2](#)

Cable

- Fiber Budget [A-3](#)
- Cable specifications
 - 1000BASE-FX network [2-2](#)
 - 1000BASE-T network [2-2](#)
 - 100BASE-T network [2-2](#)
 - 10BASE-T network [2-1](#)

Cables

- high-speed stacking [3-9](#)

CLI commands

- introduction to [1-5](#)

Connecting to the network [3-19](#)

Connectivity

- introduction to [1-4](#)

Console port

- pinout assignments [A-3](#)

D

- Document conventions [xv](#)

F

- Fiber budget [A-3](#)
- Front panel [1-2](#), [1-3](#)

H

- High-speed stack connections
 - introduction to [1-3](#)
- High-speed stacking cables
 - installation of [3-9](#)

I

Installation

- connecting to the network [3-19](#)
- high-speed stacking cables [3-9](#)
- in a rack [3-8](#)

- new stack [3-11](#)
 - new switch in existing stack [3-12](#)
 - optional Mini-GBIC [3-2](#)
- ## Installation site
- what is needed at the [3-7](#)

L

LANVIEW Diagnostic LEDs

- introduction to [1-5](#)

LANVIEW LEDs [4-2](#)

Link LEDs

- viewing of [4-2](#)

Local Management

- introduction to [1-5](#)

M

Management

- use of [1-5](#)

Mini-GBIC

- installation of [3-2](#)
- removal of [3-5](#)

Mini-GBIC input/outputs

- specifications for [A-3](#)

P

PD (Powered Device)

- introduction to [1-4](#)

PDC (Powered Device Classification)

- introduction to [1-4](#)

- list of [1-4](#)

Pinout assignments

- console port [A-3](#)

PoE (Power over Ethernet)

- introduction to [1-4](#)

PoE power

- connecting to [3-14](#)

Power connection

- AC [3-12](#)

R

Rackmount installation

- guidelines for [3-8](#)

Receive/Transmit LEDs

- viewing of [4-2](#)

Redundant Power Supply capability

- introduction to [1-3](#)

Regulatory compliance [A-4](#)

Related manuals [xiv](#)

Reset switch

- use of [4-7](#)

S

Specifications [A-1](#)

- C3G124-24P [A-1](#)

- C3G124-48P [A-2](#)

- Mini-GBIC input/outputs [A-3](#)

Stack initialization

- Manager switch selection [3-14](#)

Stack Manager

- automatic selection of [3-14](#)

Stack Member

- automatic selection of [3-14](#)

Stack operation

- Member switch selection [3-14](#)

Stack system

- installation of a new switch in an existing [3-12](#)

- installation of new [3-11](#)

Stacking cables

- introduction to [3-9](#)

Standards compatibility [1-5](#)

Switch carton

- contents of [3-2](#)
- unpacking of [3-2](#)

Switch operation

- stack installation [3-10](#)

Switches

- overview of [1-1](#)
- specifications for [A-1](#)

T

Troubleshooting [4-2](#)

- checklist [4-6](#)

U

- Unpacking the module [3-2](#)

V

Viewing receive and transmit activity

- instructions for [4-2](#)

W

WebView

- introduction to [1-5](#)

